

# DUOPRINT

Operating Manual



Copyright by Carl Valentin GmbH / 7981005.0816

Information on the scope of delivery, appearance, performance, dimensions and weight reflect our knowledge at the time of printing.

We reserve the rights to make modifications.

All rights, including those regarding the translation, are reserved.

No part of this document may be reproduced in any form (print, photocopy or any other method) or edited, copied or distributed electronically without written permission from Carl Valentin GmbH.

Due to the constant further development of our devices discrepancies between manual and device can occur.

Please check [www.carl-valentin.de](http://www.carl-valentin.de) for the latest update.

### **Trademarks**

All named brands or trademarks are registered brands or registered trademarks of their respective owners and may not be separately labelled. It must not be concluded from the missing labelling that it is not a registered brand or a registered trademark.

Carl Valentin label printers comply with the following safety guidelines:

**CE** EG-Niederspannungsrichtlinie (2006/95/EG)  
EG-Richtlinie Elektromagnetische Verträglichkeit (2004/108/EG)



### **Carl Valentin GmbH**

Postfach 3744  
D-78026 Villingen-Schwenningen  
Neckarstraße 78 – 86 u. 94  
D-78056 Villingen-Schwenningen

Phone +49 7720 9712-0  
Fax +49 7720 9712-9901

E-Mail [info@carl-valentin.de](mailto:info@carl-valentin.de)  
Internet [www.carl-valentin.de](http://www.carl-valentin.de)

## Table of Contents

|  |           |
|--|-----------|
| <b>Table of Contents</b> .....                       | <b>3</b>  |
| <b>1 Introduction</b> .....                          | <b>5</b>  |
| 1.1 General Instructions .....                       | 5         |
| 1.2 Intended Use .....                               | 5         |
| 1.3 Product Description .....                        | 6         |
| <b>2 Safety Instructions</b> .....                   | <b>7</b>  |
| 2.1 Operating Conditions .....                       | 8         |
| <b>3 Two-colour printing</b> .....                   | <b>13</b> |
| 3.1 Label Design.....                                | 13        |
| 3.2 Printhead 2 Offset.....                          | 14        |
| 3.3 Label Photocells .....                           | 14        |
| 3.4 Test Print .....                                 | 15        |
| 3.5 Correcting the Printout .....                    | 15        |
| 3.6 Material Savings - Labels .....                  | 15        |
| 3.7 Colour Processing .....                          | 16        |
| 3.8 Error Correction .....                           | 17        |
| <b>4 Technical Data</b> .....                        | <b>19</b> |
| 4.1 Accessories .....                                | 21        |
| 4.2 Control inputs and outputs .....                 | 22        |
| <b>5 Installation</b> .....                          | <b>27</b> |
| 5.1 Setting up the Label Printer .....               | 27        |
| 5.2 Connecting the Label Printer .....               | 28        |
| 5.3 Connector Pin Assignment (Printer Rear) .....    | 28        |
| 5.4 Start-Up .....                                   | 29        |
| <b>6 Loading Media</b> .....                         | <b>31</b> |
| 6.1 Loading Label Roll.....                          | 31        |
| 6.2 Loading Label Roll with Option PA 8X .....       | 32        |
| 6.3 Loading Transfer Ribbon.....                     | 33        |
| <b>7 Function Menu</b> .....                         | <b>35</b> |
| 7.1 Keyboard .....                                   | 35        |
| 7.2 Menu Structure .....                             | 36        |
| 7.3 Print settings .....                             | 39        |
| 7.4 Label layout .....                               | 40        |
| 7.5 Device settings .....                            | 42        |
| 7.6 Dispenser I/O (option) .....                     | 44        |
| 7.7 Material Savings .....                           | 48        |
| 7.8 Network .....                                    | 50        |
| 7.9 Remote console.....                              | 50        |
| 7.10 Interface.....                                  | 51        |
| 7.11 Date & Time.....                                | 52        |
| 7.12 Service Functions .....                         | 53        |
| 7.13 Main menu.....                                  | 57        |
| <b>8 Compact Flash Card / USB Memory Stick</b> ..... | <b>59</b> |
| 8.1 General Information.....                         | 59        |
| 8.2 Display Structure .....                          | 59        |
| 8.3 Navigation.....                                  | 60        |
| 8.4 Define User Directory .....                      | 61        |
| 8.5 Load Layout.....                                 | 62        |
| 8.6 File Explorer .....                              | 63        |
| 8.7 Firmware Update .....                            | 68        |
| 8.8 Filter.....                                      | 68        |

|           |  |           |
|-----------|--|-----------|
| <b>9</b>  | <b>Maintenance and Cleaning .....</b>            | <b>69</b> |
| 9.1       | General Cleaning.....                            | 70        |
| 9.2       | Cleaning the Transfer Ribbon Drawing Roller..... | 70        |
| 9.3       | Cleaning the Printer Roller .....                | 70        |
| 9.4       | Cleaning the Printhead.....                      | 72        |
| 9.5       | Cleaning the Label Photocell.....                | 73        |
| 9.6       | Replacing the Printhead .....                    | 74        |
| 9.7       | Adjusting the Printhead .....                    | 76        |
| <b>10</b> | <b>Error correction .....</b>                    | <b>79</b> |
| <b>11</b> | <b>Additional Information .....</b>              | <b>87</b> |
| 11.1      | Column Printing.....                             | 87        |
| 11.2      | Password Protection.....                         | 88        |
| 11.3      | Photocells .....                                 | 90        |
| <b>12</b> | <b>Environmentally-Friendly Disposal .....</b>   | <b>91</b> |
| <b>13</b> | <b>Index .....</b>                               | <b>93</b> |

# 1 Introduction

## 1.1 General Instructions

Important information and instructions in this document are designated as follows:



**DANGER** identifies an extraordinarily great and immediate danger which could lead to serious injury or even death.



**WARNING** identifies a possible danger which could lead to serious bodily injury or even death if sufficient precautions are not taken.



**CAUTION** indicates a potentially dangerous situation which could lead to moderate or light bodily injury or damage to property.



**NOTICE** gives you tips. They make a working sequence easier or draw attention to important working processes.



Gives you tips on protecting the environment.



Handling instruction



Optional accessories, special fittings

Time

Information in the display

## 1.2 Intended Use

The label printer is a state-of-the-art device which complies with the recognized safety-related rules and regulations. Despite this, a danger to life and limb of the user or third parties could arise and the label printer or other property could be damaged while operating the device.

The label printer may only be used while in proper working order and for the intended purpose. Users must be safe, aware of potential dangers and must comply with the operating instructions. Faults, in particular those which affect safety, must be remedied immediately.

The label printer is solely intended to print suitable media which have been approved by the manufacturer. Any other or additional use is not intended. The manufacturer/supplier is not liable for damage resulting from misuse. Any misuse is at your own risk.

Intended used includes heeding the operating manual, including the maintenance recommendations/regulations specified by the manufacturer.

**NOTICE!**

The complete documentation is included in the scope of delivery on CD ROM and can also currently be found in the internet.

### 1.3 Product Description

The label printer provides the ideal solution in which labels as well as textiles and plastics can be printed in two colours with one working process. With two printheads arranged one behind the other, labels are printed with two different colours. The second printing unit is equipped with ribbon saving function by default, i.e. the printhead is raised and the transfer ribbon consumption is reduced to a minimum.

With 8 vector fonts, 6 bitmap fonts and 6 proportional fonts the label printer has a large selection at different font types. It can be printed inverse, in italic format or 90 degrees turned fonts.

The handling of our durable label printers is easy and comfortable. The parameter settings are made with the keys of the foil keyboard. At each time the display shows the current status.

Time-saving printer update is possible by interface. The label printer is equipped with all usual interfaces such as Centronics, RS-232 as well as USB 2.0 and Ethernet 10/100 Base-T. Two additional USB ports for keyboard or scanner are also integrated as standard. The label printer automatically recognizes by which interface it is controlled

The label printer is delivered with a printer driver and the free label software Labelstar Office LITE. The software controls which parts of the label are printed by the first or second printing unit. Existing labels can be saved to a CF card or an USB stick, opened and/or modified with a PC keyboard and finally stand-alone printed.

## 2 Safety Instructions

The label printer is designed for power supply systems of 110-230 V. Connect the label printer only to electrical outlets with a ground contact.

Couple the label printer to devices using extra low voltage only.

Before making or undoing connections, switch off all devices involved (computer, printer, accessories etc.).

Operate the label printer in a dry environment only and do not get it wet (sprayed water, mist etc.).

Do not operate the label printer in explosive atmosphere and not in proximity of high voltage power lines.

Operate the label printer only in an environment protected against abrasive dust, swarf and other similar impurity.

In case of cleaning and maintenance with an open cover, ensure that clothing, hair, jewellery and similar personal items do not contact the exposed rotating parts.

The print unit can get hot during printing. Do not touch the printhead during operation. Cool down the print unit before changing material, removal or adjustment.

Carry out only the actions described in these operating instructions. Any work beyond this may only be performed by the manufacturer or upon agreement with the manufacturer.

Unauthorized interference with electronic modules or their software can cause malfunctions.

Other unauthorized work or modifications to the label printer can endanger operational safety.

Always have service work done in a qualified workshop, where the personnel have the technical knowledge and tools required to do the necessary work.

There are warning stickers on the label printers that draw your attention to dangers. Therefore the warning stickers are not to be removed as then you and others cannot be aware of dangers and may be injured.



### **DANGER!**

Danger to life and limb from power supply!

⇒ Do not open the casing.

## 2.1 Operating Conditions

**Before initial operation and during operation** these operating conditions have to be observed to guarantee safe and interference-free service of our printers.

Therefore please carefully read these operating conditions.

Shipment and storage of our printers are **only** allowed in original packing.

Installation and initial operation of printer is only allowed if operating conditions were **fulfilled**.

Initial operation, programming, operation, cleaning and service of our printers are only recommended after careful study of our manuals.

Operation of printer is only allowed by especially trained persons.



### NOTICE!

Perform trainings regularly.

Content of the training are chapter 2.1 (Operating Conditions), chapter 6 (Loading Media) and chapter 9 (Maintenance and Cleaning).

These indications are also valid for someone else's equipment supplied by us.

Only use original spare and exchange parts.

Please contact the manufacturer with respect to spare/wear parts.

### Conditions for installation place

The installation place of printer should be even, free of vibration and currents of air are to be avoided.

The printers have to be installed to ensure optimal operation and servicing.

### Installation of power supply

The installation of the power supply to connect our printers has to be effected according to the international rules and regulations, especially the recommendations of one of the three following commissions:

- International Electronic Commission (IEC)
- European Committee for Electro technical Standardisation (CENELEC)
- Verband Deutscher Elektrotechniker (VDE)

Our printers are constructed according to VDE and have to be connected to a grounded conductor. The power supply has to be equipped with a grounded conductor to eliminate internal interfering voltage.



**Technical data of power supply**

Power line voltage and power line frequency: See type plate

Allowable tolerance of power line voltage:  
+6% ... -10% of nominal value

Allowable tolerance of power line frequency:  
+2% ... -2% of nominal value

Allowable distortion factor of power line voltage:  $\leq 5\%$

**Anti-interference measures**

In case your net is infected (e.g. by using thyristor controlled machines) anti-interference measures have to be taken. You can use one of the following possibilities:

- Provide separate power supply to our printers.
- In case of problems please connect capacity-decoupled isolation transformer or similar interference suppressor in front of our printers.

**Stray radiation and immunity from disturbance**

Emitted interference according to EN 61000-6-3: 2007 industrial sector

- Interference voltage to wires according to EN 55022: 09-2003
- Interference field power according to EN 55022: 09-2003
- System perturbation according to EN 61000-3-2: 09-2006
- Flicker according to EN 61000-3-3: 1955 + A1:2001 + A2:2005

**Stray radiation and immunity from disturbance**

Immunity to interference according to EN 61000-6-2: 2005 industrial sector

- Stray radiation against discharge of static electricity according to EN 61000-4-2: 12-2001
- Electromagnetic fields according to EN 61000-4-3: 11-2003, ENV 50204: 03-1995
- Fast transient burst according to EN 61000-4-4: 07-2005
- Surge according to EN 61000-4-5: 12-2001
- High-frequency tension according to EN 61000-4-6: 12-2001
- Voltage interruption and voltage drop according to EN 61000-4-11: 02-2005

**NOTICE!**

This is a machine of type A. This machine can cause interferences in residential areas; in this case it can be required from operator to accomplish appropriate measures and be responsible for it.

**Connecting lines to external machines**

All connecting lines have to be guided in shielded lines. Shielding has to be connected on both sides to the corner shell.

It is not allowed to guide lines parallel to power lines. If a parallel guiding cannot be avoided a distance of at least 0.5 m has to be observed.

Temperature of lines between: -15 ... +80 °C.

It is only allowed to connect devices which fulfil the request 'Safety Extra Low Voltage' (SELV). These are generally devices which are checked corresponding to EN 60950.

**Installation of data lines**

The data cables must be completely protected and provide with metal or metallised connector housings. Shielded cables and connectors are necessary, in order to avoid radiant emittance and receipt of electrical disturbances.

**Allowable lines**

Shielded line:

4 x 2 x 0,14 mm<sup>2</sup> ( 4 x 2 x AWG 26)

6 x 2 x 0,14 mm<sup>2</sup> ( 6 x 2 x AWG 26)

12 x 2 x 0,14 mm<sup>2</sup> (12 x 2 x AWG 26)

Sending and receiving lines have to be twisted in pairs.

Maximum line length:

with interface V 24 (RS-232C) - 3 m (with shielding)

with Centronics - 3 m (with shielding)

USB - 3 m

Ethernet - 100 m

**Air convection**

To avoid inadmissible heating, free air convection has to be ensured.

**Limit values**

Protection according IP: 20

Ambient temperature °C (operation): Min. +5 Max. +35

Ambient temperature °C (storage): Min. -20 Max. +60

Relative air humidity % (operation): Max. 80

Relative air humidity % (storage): Max. 80  
(bedewing of printers not allowed)

**Guarantee**

We do not take any responsibility for damage caused by:

- Ignoring our operating conditions and operating manual.
- Incorrect electric installation of environment.
- Building alterations of our printers.
- Incorrect programming and operation.
- Not performed data protection.
- Using of not original spare parts and accessories.
- Natural wear and tear.

When (re)installing or programming our printers please control the new settings by test running and test printing. Herewith you avoid faulty results, reports and evaluation.

Only specially trained staff is allowed to operate the printers.

Control the correct handling of our products and repeat training.

We do not guarantee that all features described in this manual exist in all models. Caused by our efforts to continue further development and improvement, technical data might change without notice.

By further developments or regulations of the country illustrations and examples shown in the manual can be different from the delivered model.

Please pay attention to the information about admissible print media and the notes to the printer maintenance, in order to avoid damages or premature wear.

We endeavoured to write this manual in an understandable form to give and you as much as possible information. If you have any queries or if you discover errors, please inform us to give us the possibility to correct and improve our manual.



### 3 Two-colour printing

For printing in a second colour, the DuoPrint is equipped with an additional printing unit.

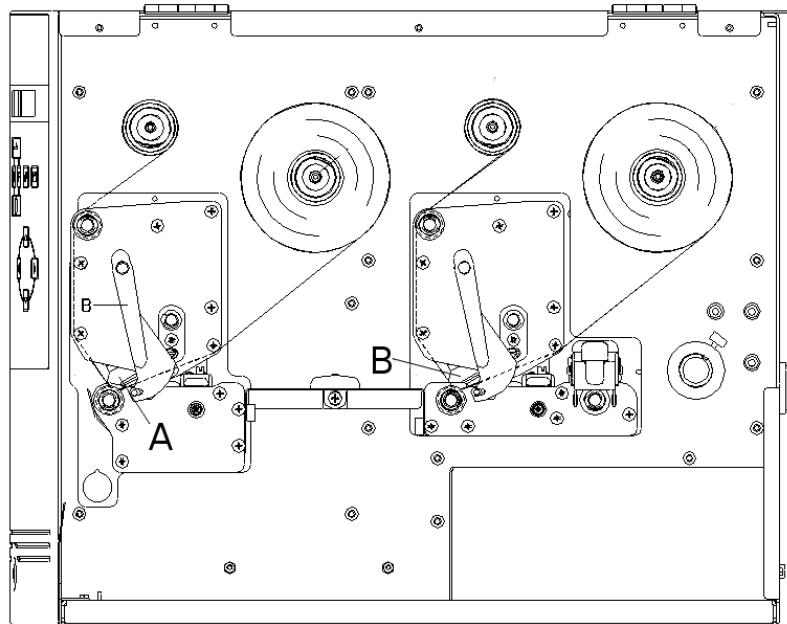

**Figure 1**

A = Front printhead

B = Rear printhead

#### 3.1 Label Design

When creating a label, it must, in addition to the contents to be printed, also be determined which contents are to be printed in the second colour, i.e. by the rear printhead.

The procedure depends on the transfer of the label.

##### Creation and printing by using Labelstar PLUS

In Labelstar PLUS, it is not possible to highlight the objects to be printed by using colours. Therefore, objects which are to be printed by the rear printhead must be specifically marked. Mark the object by using the right mouse button, select *Properties* from the context menu and activate the check box *Printhead 2* on the tab *General*.

For an optimum print result, integrated graphics must be available as black and white graphics and be separated if necessary.

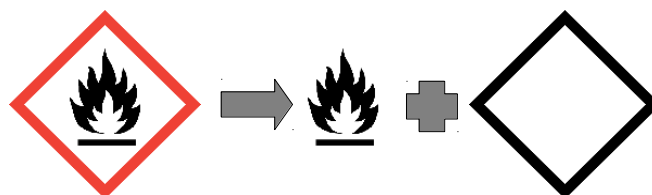

### **Creation by using (Windows) software Labelstar Office and printing via the CV printer driver**

It is possible to design labels as desired. Coloured contents in a defined colour are recognised by the driver and edited for the rear printhead.

Further information on the settings can be found in the printer driver's help menu.



#### **NOTICE!**

When creating the label, attention must be paid to the correct setting of the label size and slot length. Incorrectly set values may result in an offset within the print image.

### **Printer-internal variables**



#### **NOTE!**

It is not possible to use internal counters and date variables on the rear printhead as they are updated only at print start.

## **3.2 Printhead 2 Offset**

For optimising the print image, an automatic offset can be set for the rear printhead. Under *Service Functions/PH2 Offset*, a x- and a y-offset can be set.

Changes to this parameter alter the relative adjustment of the print contents of the front and rear printheads.

## **3.3 Label Photocells**

Each printhead has its own label light barrier in order to identify the beginning of the label. Depending on the type of material, the light barriers require different level values, which can be set separately.



#### **NOTICE!**

The two level values must be set correctly otherwise, the prints may be incorrect.

### 3.4 Test Print

The print is only ever printed at one of the two printheads. The output is controlled by the state of the rear printhead.

Printhead down = The test print is printed at the rear printhead.

Printhead up = The test print is printed at the front printhead.

### 3.5 Correcting the Printout

Mechanical tolerances may result in a shift in the printout. These deviations can be corrected temporarily by setting the X and Y offsets.

The set offset has an effect on both printheads. With the function *Printhead 2 Offset* the printouts of the front printhead and the rear printhead can be corrected to each other.

A permanent shift of the printout is possible with the menu *Service functions/Zero point adjustment*.

### 3.6 Material Savings - Labels

As the print images are printed at different positions on the label, a minimal amount of label material is lost when the printing process has been started. This is unavoidable, since rewinding the label material is not possible for reasons of a safe material feeding process.

In order to prevent material losses during the ongoing print job, it is possible to activate the *Label Save Mode*. More settings can be specified in the menu *Material savings/Label save mode*.

#### Mode: Dialog

After a label is completely printed the printer examines whether sufficient data is available in order to print the next label completely. If this is not the case then the printing is stopped.

If a follow-up order is transferred the print is continued automatically without a loss of material.

By pressing the key  the waiting status is terminated and all remaining labels between the printheads are printed. Afterwards are blank labels between the printhead. At a later print start this leads to a loss of material.

#### Mode: Auto

Stopping the print at missing data is effected in the same way as in operating mode *Dialog*.

If no further data follow the remaining labels are printed automatically after an adjusted time.

The waiting time is to be set in menu *Material saving/Auto feed delay*.

The waiting time should not be set longer than 2 - 3 seconds, otherwise this could lead to irritations for the operator.

**Mode: I/O**

Print stop at missing data is effected in the same way as in mode *Dialog*. However, no indication of waiting state is shown at the display only the output *Waiting state* is set.

As long as no subsequent print order is transferred the *Print start* input is inactive. After transferring a subsequent print order the print is started only after setting the *Print start* signal.

The waiting status is left by pressing the key  or by setting the signal *Terminate waiting state*.

In the dispensing modes this mode is activated automatically except the mode *Off* is active.

**Mode: Off**

No examination is effected whether further data is presented. All presented labels are completely printed immediately.

This mode is not recommended with slow data connections or closely printed labels as it can come to a loss of material within a print order.

In the dispensing modes is this mode activated automatically.

### 3.7 Colour Processing

In two-colour printing procedure the incoming data are printed according to the transmitted field attributes on the front or rear printhead.

With the parameter *Colour processing* it can be set that all data are printed only on the front printhead or only on the rear printhead. The field attributes are ignored in this mode.

The label material is to be inserted in all operating modes as in the two-colour mode. I.e. the label material is to be guided through both photocells and the rear transport unit must be closed.

**Operating mode „only print to the front“ (Print to PH1)**

Select *Standard* in the *Material Savings* menu to avoid the transfer ribbon consumption at the rear printhead.

The number of advance labels is reduced. For technical reasons and depending on the label size, 1 or two 2 advance labels are necessary.



**Operating mode „print only on the rear“ (Print to PH2)**

The front printhead is opened to avoid a paper jam.

**CAUTION!**

Paper jam between the rear and the front printhead.

⇒ Pay attention to a safe label guiding.  
We recommend using a rewinder unit.

The loss of material is the same as with two-colour printing as the printed labels are forwarded to the tear-off edge. The loss of material can be reduced (see chapter 3.6, page 15).

The transfer ribbon at the front printhead can be removed.

The restrictions are valid when using printer-internal variables (see page 14).

**3.8 Error Correction**

In the event of recoverable errors such as transfer ribbon errors, the printing process can be continued after the error has been corrected. If the printhead was opened in order to remove the cause then all labels which have not yet been completed are printed again.



## 4 Technical Data

|  | DuoPrint 107/12   | DuoPrint 160/12          |
|--|---|--------------------------|
| Print Resolution                                     | 305 dpi   | 305 dpi                  |
| Max. Print Speed                                     | 150 mm/s  | 120 mm/s                 |
| Print Width  | 106,6 mm  | 160 mm                   |
| Passage Width  | 116 mm  | 176 mm                   |
| Printhead  | Corner Type   | Corner Type              |
| <b>Labels</b>  |   |                          |
| Labels/Continuous Material                           | Paper, Cardboard, Textile, Synthetics                           |                          |
| Max. Material Weight                                 | 220 g/m <sup>2</sup> (higher on demand)                         |                          |
| Min. Label Width                                     | 15 mm   | 50 mm                    |
| Min. Label Height                                    | 25 mm   | 25 mm                    |
| Max. Label Height                                    | 1200 mm / 1100 mm (Option)                                      | 800 mm / 700 mm (Option) |
| Max. Roll Diameter                                   | External unwinder: 300 mm<br>External rewinder: 300 mm (Option) |                          |
| Core Diameter  | 40 mm / 75 mm (Option)  | 40 mm / 75 mm (Option)   |
| Winding  | Outside or inside   | Outside or inside        |
| Label Sensor   | Transmission + Reflexion from below                             |                          |
| <b>Transfer Ribbon</b>                               |   |                          |
| Ink  | Outside or inside   | Outside or inside        |
| Max. Roll Diameter                                   | Ø 90 mm   | Ø 90 mm                  |
| Core Diameter  | 25,4 mm / 1"  | 25,4 mm / 1"             |
| Max. Length  | 450 m   | 450 m                    |
| Max. Width   | 110 mm  | 163 mm                   |
| <b>Dimensions (mm)</b>                               |   |                          |
| Width x Height x Depth                               | 275 x 380 x 475   | 335 x 380 x 475          |
| Weight   | ca. 22 kg   | ca. 27 kg                |
| <b>Dimensions (mm) with option external rewinder</b> |   |                          |
| Width x Height x Depth                               | 275 x 410 x 825   | 335 x 410 x 825          |
| Weight   | ca. 24,5 kg   | ca. 29,8 kg              |
| <b>Electronics</b>                                   |   |                          |
| Processor  | High Speed 32 Bit   |                          |
| RAM  | 16 MB   |                          |
| Slot   | For Compact Flash carte type I                                  |                          |
| Battery Cache  | For Real-Time clock (storage of data with shut-down)            |                          |
| Warning Signal                                       | Acoustic signal when error                                      |                          |
| <b>Interfaces</b>                                    |   |                          |
| Serial   | RS-232C (up to 115200 Baud)                                     |                          |
| Parallel   | Centronics (SPP)  |                          |
| USB  | 2.0 High Speed Slave  |                          |
| Ethernet   | 10/100 Base T, LPD, RawIP-Printing, DHCP, HTTP, FTP             |                          |
| 2 x USB Master                                       | Connection for external USB keyboard and memory stick           |                          |
| <b>Operation Data</b>                                |   |                          |
| Power Supply   | 110 ... 230 V / 50 ... 60 Hz                                    |                          |
| Max. Power Consumption                               | 600 VA  |                          |
| Nominal Current                                      | 230 V - 1,5 A / 110 V - 3 A                                     |                          |
| Fuse Values  | 230 V - 3,15 A / 110 V - 5 A                                    |                          |
| Operating Temperature                                | 5 ... 35 °C   |                          |
| Max. Humidity  | 80% (not condensing)  |                          |

| <b>Operation Panel</b>      |   |
|-----------------------------|---|
| Keys                        | Test print, function menu, quantity, CF Card, feed, enter, 4 x cursor   |
| LCD Display                 | Graphic display 132 x 64 Pixel - white backlight  |
| <b>Settings</b>             |   |
|                             | Date, time, shift times<br>11 language settings (others on demand)<br>Label and device parameters, interfaces, password protection, variables   |
| <b>Monitoring</b>           |   |
| Stop printing if            | End of ribbon / end of labels / printhead open  |
| Status report               | Extensive status print with information about settings e.g. print length counter, runtime counter, photocell interface and network parameters<br>Printout of all internal fonts and all supported bar codes   |
| <b>Fonts</b>                |   |
| Font types                  | 6 Bitmap fonts<br>8 Vector fonts/TrueType fonts<br>6 proportional fonts<br>Other fonts on demand  |
| Character sets              | Windows 1250 up to 1257, DOS 437, 850, 852, 857<br>All West and East European Latin, Cyrillic, Greek and Arabic (option) characters are supported<br>Other character sets on demand   |
| Bitmap fonts                | Size in width and height 0,8 5,6<br>Zoom 2 ... 9<br>Orientation 0°, 90°, 180°, 270°   |
| Vector fonts/TrueType fonts | Size in width and height 1 ... 99 mm<br>Variable zoom<br>Orientation 0°, 90°, 180°, 270°  |
| Font attributes             | Depending on character font - bold, Italic, Inverse, Vertical   |
| Font width                  | Variable  |
| <b>Bar Codes</b>            |   |
| 1D bar codes                | CODABAR, Code 128, Code 2/5 interleaved, Code 39, Code 39 extended, Code 93, EAN 13, EAN 8, EAN ADD ON, GS1-128, Identcode, ITF 14, Leitcode, Pharmacode, PZN 7 Code, PZN 8 Code, UPC-A, UPC-E  |
| 2D bar codes                | Aztec Code, CODABLOCK F, DataMatrix, GS1 DataMatrix, MAXICODE, PDF 417, QR Code   |
| Composite bar codes         | GS1 DataBar Expanded, GS1 DataBar Limited, GS1 DataBar Omnidirectional, GS1 DataBar Stacked, GS1 DataBar Stacked Omnidirectional, GS1 DataBar Truncated   |
|                             | All bar codes are variable in height, module width and ratio.<br>Orientation 0°, 90°, 180°, 270°.<br>Optionally with check digit and human readable line.   |
| <b>Software</b>             |   |
| Configuration               | ConfigTool  |
| Process control             | NiceLabel   |
| Label software              | Labelstar Office Lite, Labelstar Office   |
| Windows driver              | Windows 7 <sup>®</sup> 32/64 Bit, Windows 8 <sup>®</sup> 32/64 Bit<br>Windows 8.1 <sup>®</sup> 32/64 Bit, Windows 10 <sup>®</sup> 32/64 Bit,<br>Windows Server 2008 <sup>®</sup> (R2) 64 Bit<br>Windows Server 2012 <sup>®</sup> 64 Bit, Windows Server 2012 <sup>®</sup> (R2) 64 Bit |

Technical modifications are subject to change.

## 4.1 Accessories

### Standard Equipment

- Tear-off edge
- Real time clock with printout date and time  
Automatic daylight saving time  
Storage of data with shut-down
- Variables: link field, counter, date/time, calculation and shift variable, CF data
- Thermal transfer version
- USB host for connection of an external USB keyboard and an USB memory stick
- Ethernet interface
- Label photocell  
(transmission and reflexion from below)
- Compact Flash card slot
- Windows printer driver on CD ROM

### Optional Equipment

- External rewinder PR 12 / PR 17  
(max. outer diameter 300 mm)
- External unwinder PA 80 / P 81  
(max. outer diameter 300 mm)
- Dispenser I/O
- Connection set

### 4.2 Control inputs and outputs

By means of a maximum of 16 control inputs and outputs which, in the following, are also referred to as ports, different functions of the printer system can be triggered and operating states can be displayed.

The ports are provided by means of a D-Sub bushing (26pin HD) at the rear panel of the printer system and are galvanically isolated from protective earth (PE) by means of an optocoupler semi-conductor route.

Each port can be configured as input and as output. This function however, is predefined in the printer software and cannot be changed by the user.

The following parameters can be changed and set by using the menu: debounce times and high or low active.

#### Printer, internal circuitry

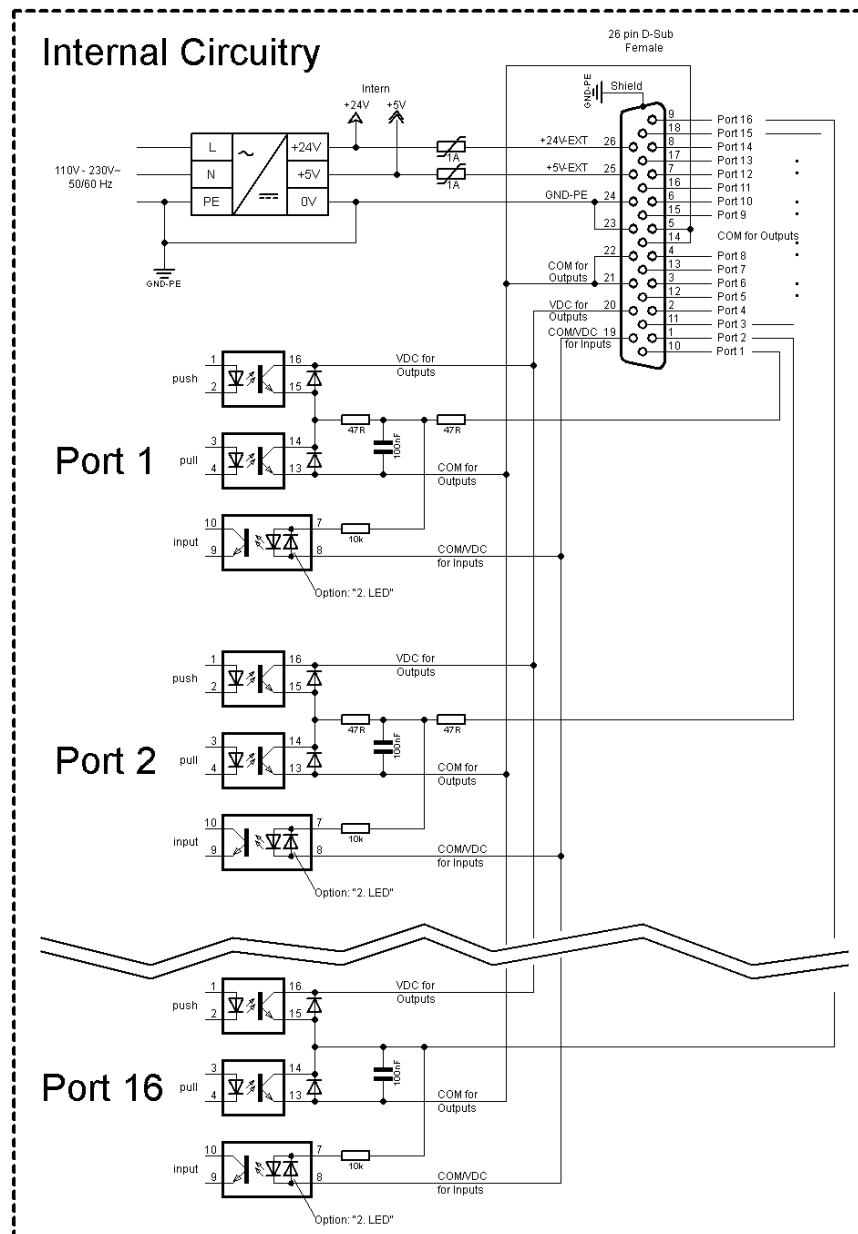
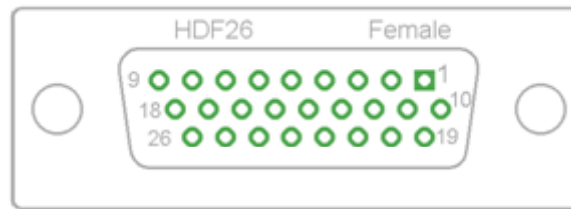

Figure 2

### Configuration of D-Sub socket



**Figure 3**

Port 1 to Port 16 = Assignment for I/O Profile 'Std\_Label'

| Identification     | Pin           | Description / Function   |
|--------------------|---------------|--|
| Port 1             | 10            | Print start (Input)  |
| Port 2             | 1             | No function  |
| Port 3             | 11            | Counter Reset (Input)  |
| Port 4             | 2             | No function  |
| Port 5             | 12            | Reset error (Input)  |
| Port 6             | 3             | Terminate waiting state (Input)  |
| Port 7             | 13            | No function  |
| Port 8             | 4             | No function  |
| Port 9             | 15            | Error (Output)   |
| Port 10            | 6             | Print order activ (Output)   |
| Port 11            | 16            | Waiting state (Output)   |
| Port 12            | 7             | Single print (Output)  |
| Port 13            | 17            | Ready (Output)   |
| Port 14            | 8             | No function  |
| Port 15            | 18            | No function  |
| Port 16            | 9             | Forerun active (Output)  |
| COM/VDC for Inputs | 19            | Common reference potential of all control inputs. 'COM/VDC for Inputs' is usually connected with the (-) terminal of the control voltage and the control inputs are switched to active (+).<br>By means of the option '2nd LED', 'COM/VDC for Inputs' can optionally be connected with the (+) terminal of the control voltage. Then, the control inputs are switched to active (-). |
| VDC for Outputs    | 20            | Common supply connection of all control outputs. 'VDC for Outputs' must be connected with the (+) terminal of the control voltage. Never leave 'VDC for Outputs' open even if no output is used.   |
| COM for Outputs    | 5,14<br>21,22 | Common reference potential of all control outputs. 'COM for Outputs' must be connected with the (-) terminal of the control voltage. Never leave 'COM for Outputs' open even if no output is used.   |
| GND-PE             | 23,24         | 'GND-PE' is the reference potential of the '+5 VDC EXT' and '+24 VDC EXT' voltages provided by the printer system.<br>'GND-PE' is printer internally connected with protective earth (PE).   |

| Identification  | Pin | Description / Function   |
|-----------------|-----|--|
| + 5 VDC<br>EXT  | 25  | 5 Volt DC output for external use. Max. 1 A.<br>This voltage is provided from direct print module and can be used e.g. as control voltage. Never apply any external voltage to this output.  |
| + 24 VDC<br>EXT | 26  | 24 Volt DC output for external use. Max. 1 A.<br>This voltage is provided from direct print module and can be used e.g. as control voltage. Never apply any external voltage to this output. |

Technical data

| Plug Connector                          |  |
|---|--|
| Type                                    | D-Sub connector High Density<br>26-pin. / connector                            |
| Manufacturer                            | W+P-Products   |
| Reference number                        | 110-26-2-1-20  |
| Output Voltages (connected with GND-PE) |  |
| + 24 V / 1 A                            | Fuse: Polyswitch / 30 V / 1 A  |
| + 5 V / 1 A                             | Fuse: Polyswitch / 30 V / 1 A  |
| Port 1 - 15                             |  |
| <b>Input</b>                            |  |
| Tension                                 | 5 VDC ... 24 VDC   |
| Impedance                               | 47Ω + (100nF    10 kΩ)   |
| <b>Output</b>                           |  |
| Tension                                 | 5 VDC ... 24 VDC   |
| Impedance                               | 47Ω + (100nF    10 kΩ    47Ω)  |
| Current max.                            | High +15 mA<br>Low -15 mA  |
| Port 16                                 |  |
| <b>Input</b>                            |  |
| Tension                                 | 5 VDC ... 24 VDC   |
| Impedance                               | 100nF    10 kΩ   |
| <b>Output</b>                           |  |
| Tension                                 | 5 VDC ... 24 VDC   |
| Impedance                               | 100nF    10 kΩ   |
| Current max.                            | High +500 mA (Darlington BCP56-16)<br>Low - 500 mA (Darlington BCP56-16)       |
| Optocoupler                             |  |
| Output                                  | TCMT4106, CTR 100% - 300%, Vishay or<br>TLP281-4(GB), CTR 100% - 600%, Toshiba |
| Input                                   | TCMT4106, CTR 100% - 300%, Vishay or<br>TLP281-4(GB), CTR 100% - 600%, Toshiba |
| Input<br>Option 2nd LED                 | TCMT4600, CTR 80% - 300%, Vishay or<br>TLP280-4, CTR 33% - 300%, Toshiba       |



**Example 1**

Device connection to a machine with S7-300 SPS.

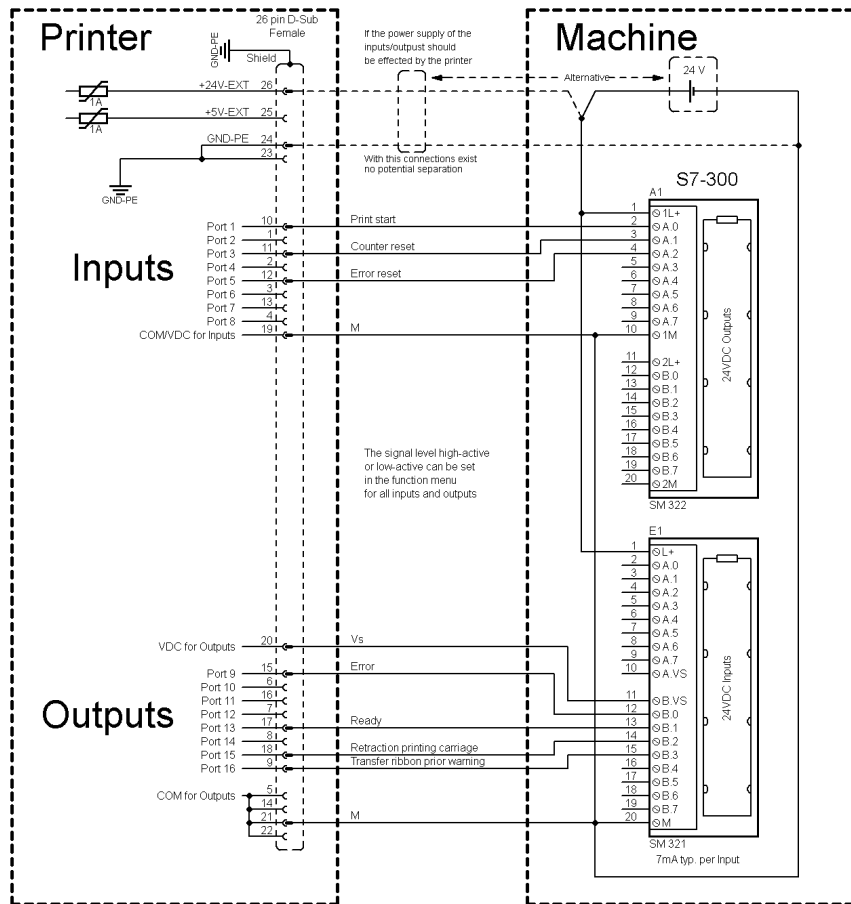

**Figure 4**

**Example 2**

Device connection to an operating panel.

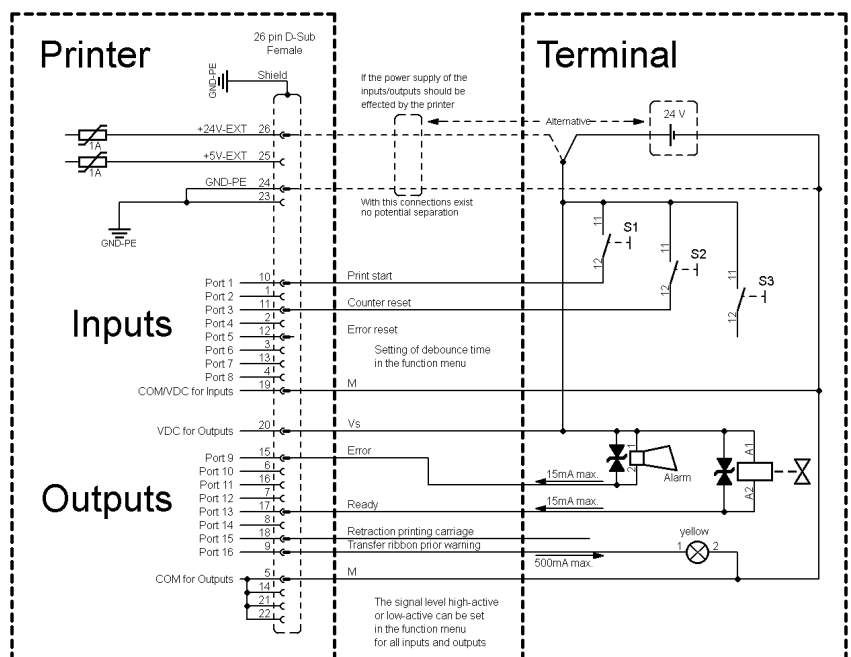

**Figure 5**

**Example 3**

Device connection version if 'Option: 2. LED'.

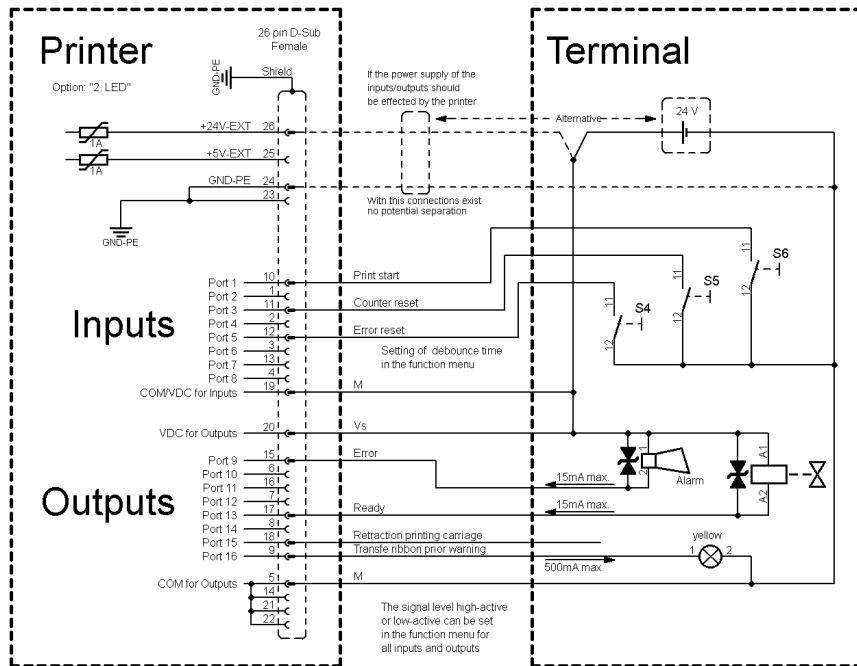

**Figure 6**

**Precautions**

When connecting a reed contact with a control input, the contact must have a switching capacity of min. 1 A in order to prevent the contact from sticking due to the inrush current. As an alternative, a suitable resistor can be connected in series.

If one of the printer's internal voltages '+5 VDC EXT' or '+24 VDC EXT' is used, an external fuse e.g. 0.5 AF, should be additionally installed to protect the printer electronics.

In the event of an inductive load, an antiparallel connected diode, for instance, must be used to discharge the induction energy.

In order to minimise the influence of leakage currents at control outputs, a resistor must, depending on what is connected, be installed in parallel with the load.

In order to avoid any damages to the printing system, the max. output currents must not be exceeded or outputs shorted.

## 5 Installation

### Unpack the label printer

- ⇒ Lift the label printer out of the box.
- ⇒ Check the label printer for transport damages.
- ⇒ Check delivery for completeness.

### Scope of delivery

- Label Printer.
- Power Cable.
- Empty core, mounted on transfer ribbon rewinder.
- Tear-off edge.
- Rewinder (optional).
- Unwinder (optional).
- Documentation.
- Printer driver on CD ROM.



#### NOTICE!

Retain original packaging for subsequent transport.

### 5.1 Setting up the Label Printer



#### CAUTION!

The label printer and the print media can be damaged by moisture and water.

- ⇒ Set up the label printer only in a dry place protected from sprayed water.
  
- ⇒ Set up label printer on a level, vibration-free and air draught-free surface.
- ⇒ Open cover of label printer.
- ⇒ Remove foam transportation safeguards near the printhead.

## 5.2 Connecting the Label Printer

### Connecting to the power supply

The label printer is equipped with a versatile power supply unit. The device may be operated with a mains voltage of 110-230V / 50-60 Hz without any adjustments or modifications.



#### CAUTION!

The label printer can be damaged by undefined switch-on currents.

⇒ Set de power switch to '0' before plugging in the label printer.

⇒ Insert power cable into power connection socket.

⇒ Insert plug of power cable into a grounded electrical outlet.

### Connecting to a computer or computer network



#### NOTICE!

Insufficient or missing grounding can cause faults during operation.

Ensure that all computers and connection cables connected to the label printer are grounded.

⇒ Connect label printer to computer or network with a suitable cable.

## 5.3 Connector Pin Assignment (Printer Rear)

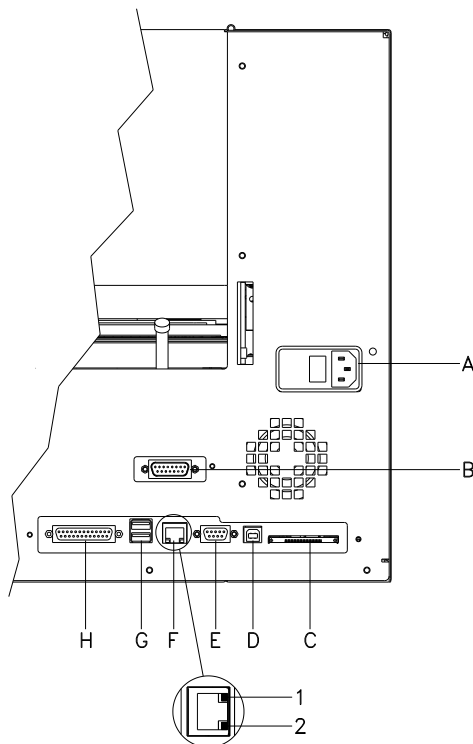

- A Power supply
- B External Output/Input (Option)
- C Compact Flash card slot
- D USB interface
- E Serial interface RS-232
- F Ethernet 10/100 interface
  - 1 = LED orange
  - Lighting = Connection active
  - Flashing = Data transfer
  - Off = No connection
  - 2 = LED green
  - Lighting: Speed 100 MBit
  - Off: Speed 10 MBit
- G USB host for USB keyboard and USB memory stick
- H Centronics

Figure 7

## 5.4 Start-Up

After all connections are made switch on the label printer.

After switching on the label printer the main menu appears which shows the printer type, current date and time.

Insert label material and transfer ribbon (see chapter 6. Loading Media, page 31).

Go to menu *Label layout*, select menu item *Measure label* and start measuring (see chapter 7.4 Label layout, page 40).

Press key  to finish measuring.



### NOTICE!

To enable correct measuring, at least two completed labels have to be passed through (not for continuous labels).

During the measuring procedure of label and gap length small differences can occur. Therefore the values can be set and transferred to the printer by means of the label design software as well as via the printer driver.



## 6 Loading Media

### 6.1 Loading Label Roll

Loading label roll  
in tear-off mode

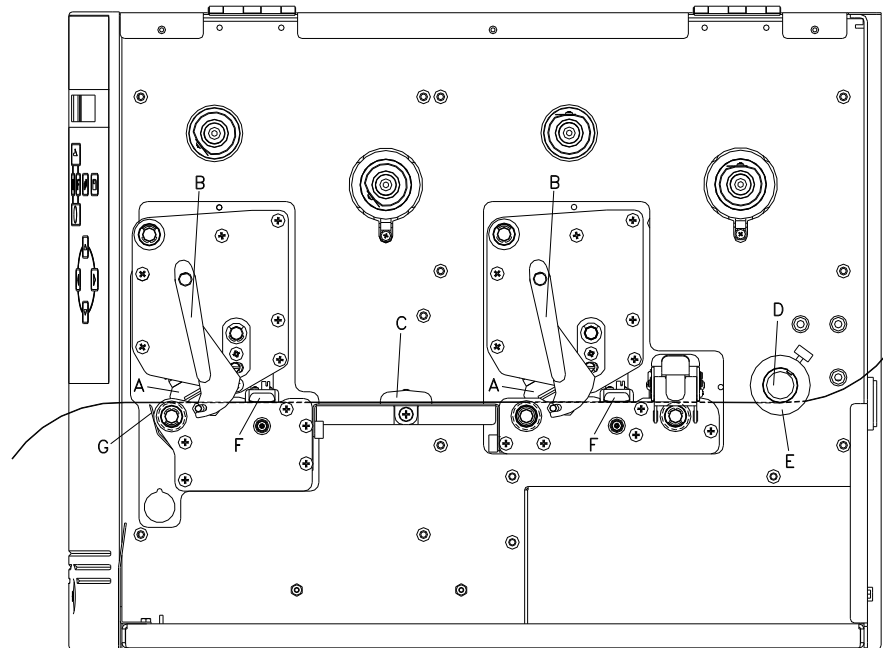

Figure 8

1. Open the printer cover.
2. Open printheads (A) by turning the red pressure levers (B) anticlockwise.
3. Remove the optional outside label mounting plate from the unwinder.
4. Load the label roll with inner winding onto the unwinding roll.
5. Attach again the label mounting plate.
6. Lead the label material below the return pulley (D) and the printheads (A). Pay attention that the label runs through the photocells (F).
7. In order to move the printheads (A) down, turn the red pressure levers (B) in clockwise direction until they lock.
8. In front of the first printhead you can see the tear off edge (G) from which you can rip off labels to the bottom.
9. Enter the offset value in the menu *Print settings/Tear-off*.
10. Adjust the adjusting ring (E) onto the return pulley (D) and the label guiding (C) to the width of material.
11. Close the printer cover.

## 6.2 Loading Label Roll with Option PA 8X

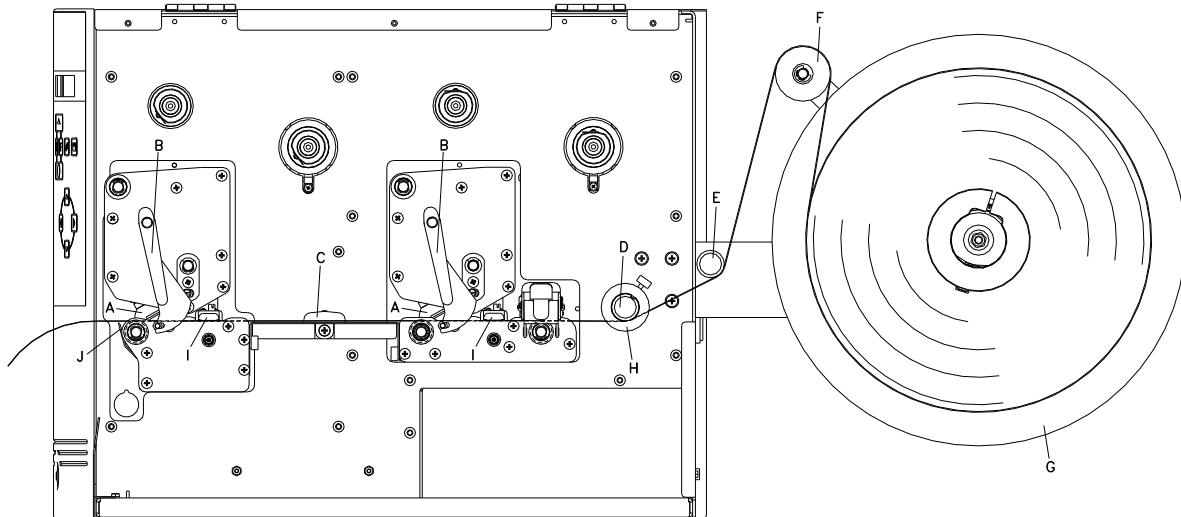

Figure 9

### Retrofit option CV label unwinder PA 8X

1. Open the printer cover.
2. Insert the CV label unwinding device PA 8X from behind in the provided cut-out in the rear wall and fasten it using 3 Philips head screws.

### Load label material

1. Turn the red pressure levers (B) anticlockwise to fold back the printheads (A).
2. Remove the outer label holding device from the optional unwinding device (G).
3. Place the label roll with inner winding on the unwinding device (G).
4. Re-install the outer label holding device.
5. Pass the label material over the dancer roll (F) and under the deflections shafts (E + D) and the printheads (A). Ensure that the material runs through the photocells (I).
6. Turn the red pressure levers (B) clockwise until they engage to fold down the printheads (A).
7. In front of the front printhead, the tear-off edge (J) can be seen.
8. Enter the offset value under the menu item *Print Initialisation/Tear-off Edge*.
9. Align the adjusting ring (H) on the deflection shaft (D) and the label guidance (C) with the material width.
10. Close the printer cover.



### 6.3 Loading Transfer Ribbon



#### NOTICE!

For the thermal transfer printing method it is necessary to load a ribbon, otherwise when using the printer in direct thermal print it is not necessary to load a ribbon.

The ribbons used in the printer have to be at least the same width as the print media. In case the ribbon is narrower than the print media, the printhead is partly unprotected and this could lead to early wear and tear.

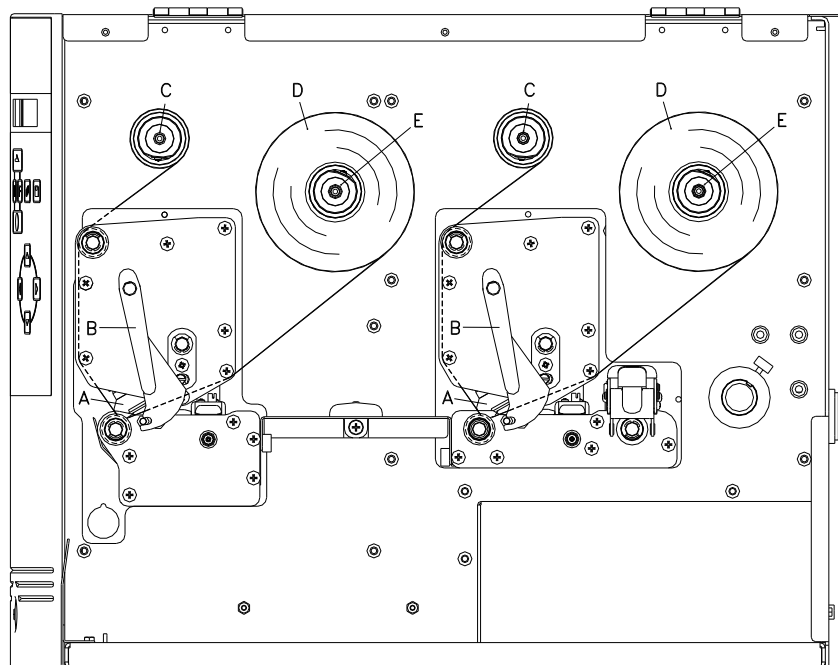

Figure 10



#### NOTICE!

Before a new transfer ribbon roll is loaded, the printhead must be cleaned using printhead and roller cleaner (97.20.002).

For more information, see page 72.

The handling instructions for the use of Isopropanol (IPA) must be observed. In the case of skin or eye contact, immediately wash off the fluid thoroughly with running water. If the irritation persists, consult a doctor. Ensure good ventilation.

1. Open the printer cover.
2. Open printheads (A) by turning the red pressure levers (B) anticlockwise.
3. Load the transfer ribbon rolls (D) with outer winding onto the unwinding rolls (E).

4. Place empty ribbon rolls onto the rewinding rolls (C) and lead the transfer ribbon below the printheads (A).
5. Fix the beginnings of each transfer ribbon with an adhesive tape in rotating direction at the empty roll of the rewinding rolls (C).  
Pay attention to the rotation direction of transfer ribbon rewinder anticlockwise.
6. In order to move the printheads (A) down, turn the red pressure levers (B) in clockwise direction until they lock.
7. Close the printer cover.

















**NOTICE!**

As for the electrostatic unloading the thin coating of the thermal printhead or other electronic parts can be damaged, the transfer ribbon should be antistatic.

The use of wrong materials can lead to printer malfunctions and the guarantee can expire.

## 7 Function Menu

### 7.1 Keyboard

|   |   |
|---|---|
|    | <p>Back to the main menu.</p> <p>Start a test print.</p> <p>Delete a stopped print order.</p>   |
|    | <p>Change to the function menu.</p> <p>In function menu: one menu item back.</p>  |
|    | <p>Change to the quantity (number of pieces) menu.</p> <p>Press keys  and  to select the number of labels that should be printed.</p> |
|    | <p>Change to the menu of the Compact Flash card.</p>  |
|    | <p>In main menu: feed of one label.</p> <p>In function menu: skip to the next menu item.</p>  |
|  | <p>Confirm settings and modifications.</p> <p>Stop and continue current print orders.</p> <p>Delete a stopped print order with key . No further label of the print order is printed.</p>                           |
|  | <p>Return to the previous input field.</p> <p>Press keys  and  to change the values.</p>  |
|  | <p>Skip to the next input field.</p> <p>Press keys  and  to change the values.</p>  |
|  | <p>Increase figure at the cursor position.</p>  |
|  | <p>Decrease figure at the cursor position.</p>  |

## 7.2 Menu Structure

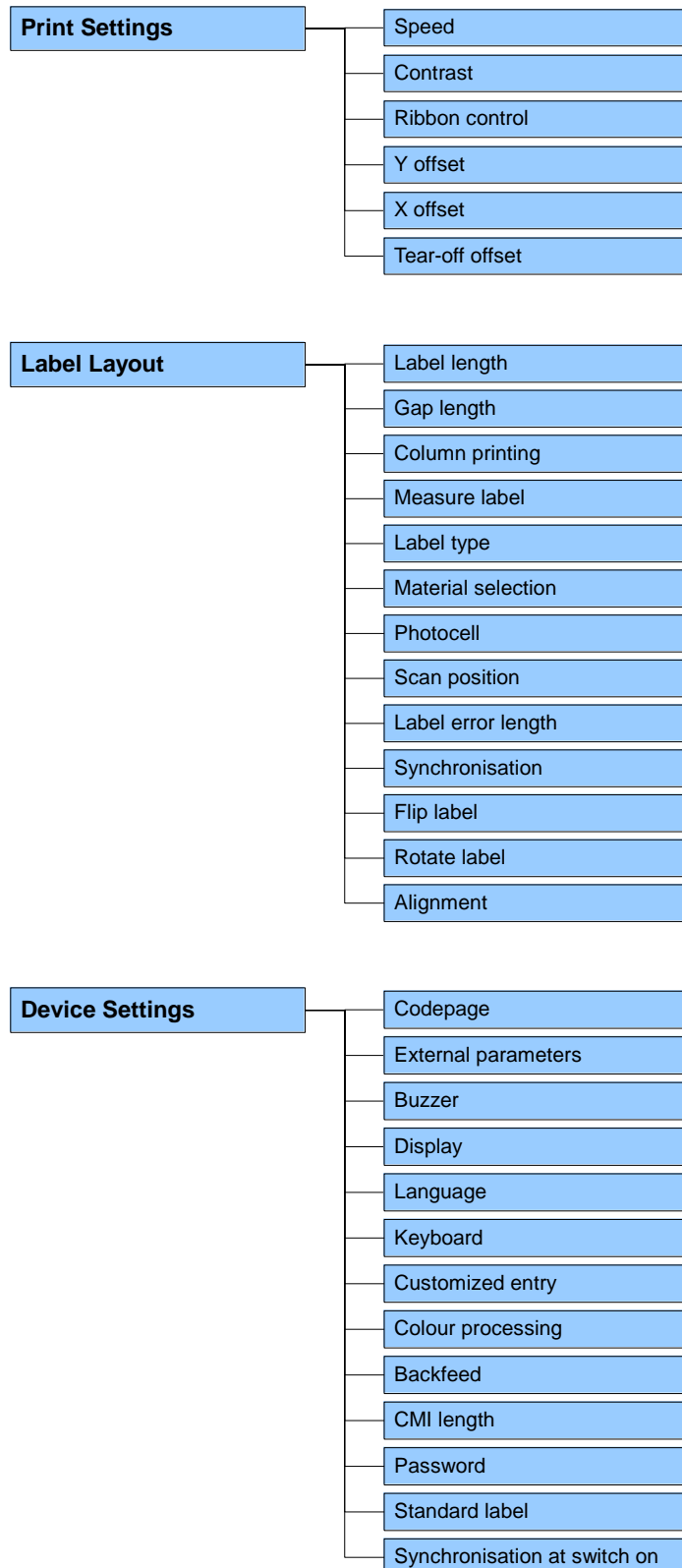

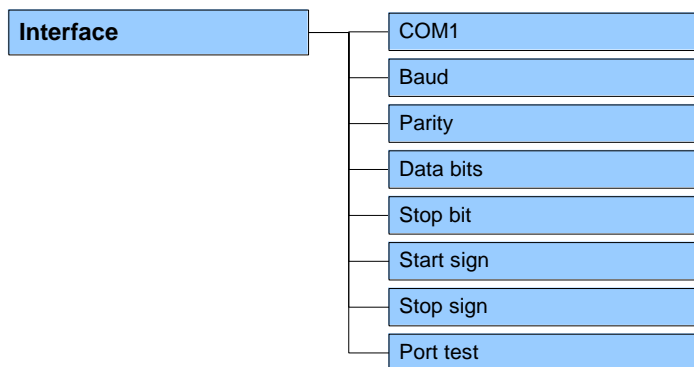
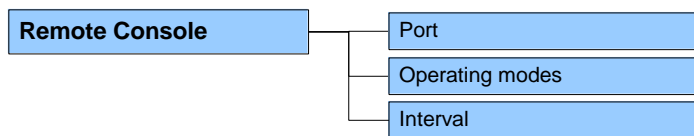
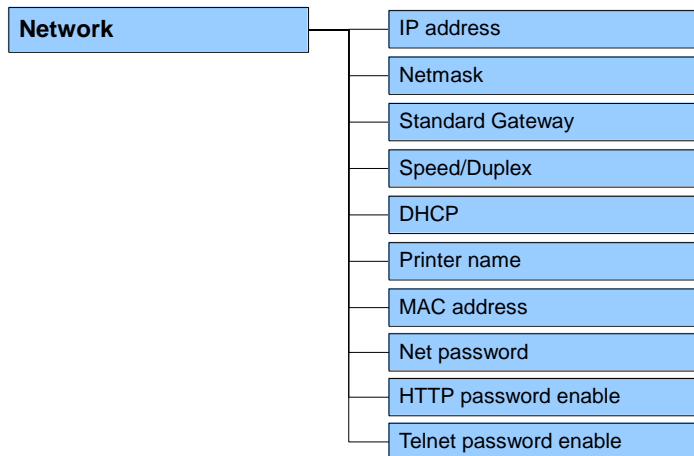
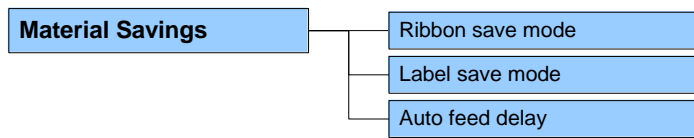
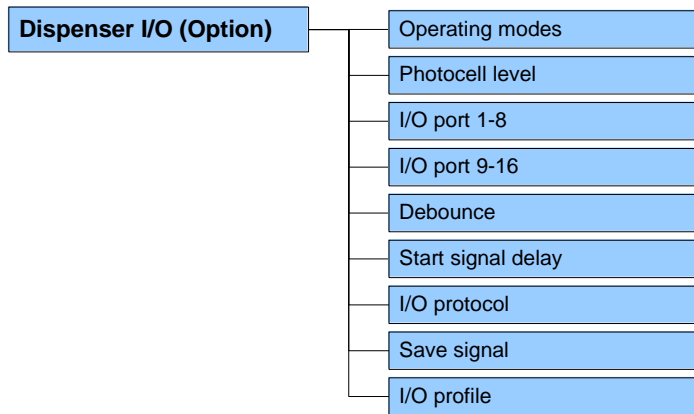

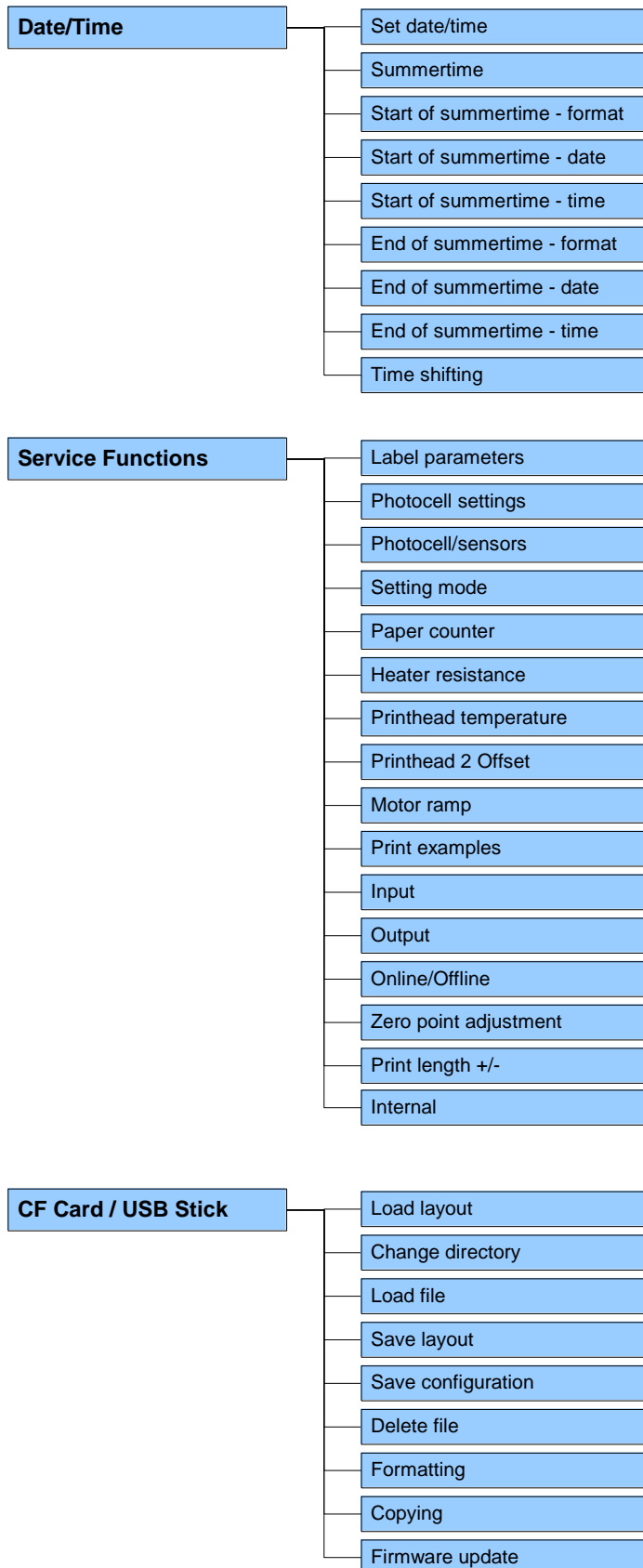

### 7.3 Print settings

Switch on the label printer and the display shows the main menu.

Press key  to access the function menu.

Press key  to select the menu *Print settings*.

#### Speed

Indication of print speed in mm/s (see chapter Technical Data, page 19). The print speed can be determined for each print order anew.

The setting of print speed affects also the test prints.

#### Contrast

Indication of value to set the print intensity when using different materials, print speeds or printing contents.

The contrast can be set for both printheads.

Value range: 10% ... 200 %.

Step size: 10%.

Press key  to arrive the next menu item.

#### Ribbon control

Examination if the transfer ribbon roll is to end or if the ribbon was torn at the unwinding roll.

**Off:** The ribbon control is deselected, i.e. the printer continues without an error message.

**On:** The ribbon control is selected, i.e. the current print order is interrupted and an Error Message appears at the printer display.

**Strong sensibility:** The printer reacts immediately to the end of the transfer ribbon.

**Weak sensibility:** The printer reacts at approx. 1/3 more slowly to the end of the transfer ribbon.

Press key  to arrive the next menu item.

#### Y displacement

Indication of initial point displacement in mm.

Displacement of the complete print in paper direction. With positive values the print in paper direction starts later.

The value is set for both printheads together.

Value range: -30.0 ... +90.0.

Press key  to arrive the next menu item.

#### X displacement

Displacement of the complete print transverse to the paper direction.

The displacement is possible only up to the edges of the printing zone and is determined by the width of the focal line in printhead.

The value is set for both printheads together.

Value range: -90.0 ... +90.0.

Press key  to arrive the next menu item.

#### Tear-off

Indication of value to which the last label of a print order is moved forward and is moved back to the beginning of label at a new print start. Labels can be torn off after terminating the print order without a label loss by tearing up.

Default value: 12 mm.

Value range: 0 ... 50.0 mm.

## 7.4 Label layout

Switch on the label printer and the display shows the main menu.

Press key  to access the function menu.

Press key  as long as you arrive the *Label layout* menu.

Press key  to select the menu.

### Label length

Indication of label length in mm  
(see chapter Technical Data, page 19).

### Gap length

Indication of distance between two labels in mm  
(not for continuous labels).  
Minimum value: 1 mm.

Press key  to arrive the next menu item.

### Column printing

Indication of width of one label as well as how many labels are placed side by side (see chapter 11.1 Column Printing, page 87).

Press key  to arrive the next menu item.

### Measure label

Press key  to start measuring. The printer stops automatically after termination of measuring. The determined values are displayed and saved.

Press key  to arrive the next menu item.

### Label type

Generally adhesive labels are set. Press key  to select continuous labels. If the menu item *Label length/Gap length* contains a gap value, this value is added to the label length..

Press key  to arrive the next menu item.

### Material selection

Selection of the used label and transfer ribbon material.

Press key  to arrive the next menu item.





### Photocell

Selection of the used photocell. The selection of one of the following photocell types is possible:  
Transmission photocell normal and inverse, reflexion photocell normal and inverse (see chapter 11.3 Photocells, page 90).

### Scan position (SP)

Entry of percental label length by that the label end is searched.  
Marks onto the label can be skipped.



- Press key  to arrive the next menu item.
- Label error length** In case an error occurs, indication after how many mm a message appears in the display.  
Value range: 1 mm ... 999 mm.
- Synchronisation** **On:** If a label is missed on the liner an error message is displayed.  
**Off:** Missing labels are ignored, i.e. it is printed into the gap.
- Press key  to arrive the next menu item.
- Flip label** The axis of reflection is in the middle of the label. If the label width was not transferred to the printer, automatically the default label width i.e. the width of the printhead is used. It is recommended to use labels with the same width as the printhead. Otherwise this can cause problems in positioning.
- Press key  to arrive the next menu item.
- Rotate label** According to standard the label is printed ahead with a rotation of 0°. If the function is activated, the label is rotated by 180° and printed in reading direction.
- Press key  to arrive the next menu item.
- Alignment** The adjustment of label is effected only after *Flip/Rotate label*, i.e. the adjustment is independent of the functions *Flip label* and *Rotate label*.  
**Left:** The label is aligned at the left-most position of printhead.  
**Centre:** The label is aligned at central point of printhead.  
**Right:** The label is aligned at right-most position of printhead.

## 7.5 Device settings

Switch on the label printer and the display shows the main menu.

Press key  to access the function menu.

Press key  as long as you arrive the *Device settings* menu.

Press key  to select the menu.

### Codepage

Indication of the font used in the printer. The following possibilities are available:

Codepage 1252 West European (former ANSI)

Codepage 437 English

Codepage 850 Western European

Codepage 852 Slavic

Codepage 857 Turkish

Codepage 1250 Central and East European

Codepage 1251 Cyrillic

Codepage 1253 Greek

Codepage 1254 Turkish

Codepage 1257 Baltic

WGL4

Please find the tables referring to the above mentioned character sets on [www.carl-valentin.de/Downloads](http://www.carl-valentin.de/Downloads).

Press key  to arrive the next menu item.

### External parameters

**Label dimension only:** The parameters for label length, gap length and label width can be transferred to the printer. All other parameter settings are to be made directly at the printer.

**On:** Sending parameters such as print speed and contrast via our label creation software to the printer. Parameters which are set directly at the printer before are no longer considered.

**Off:** Only settings made directly at the printer are considered.

Press key  to arrive the next menu item.

### Buzzer

**On:** An acoustic signal is audible when pressing a key.

Value range: 1 ... 7.

**Off:** No signal is audible.

### Display

Setting of display contrast.

Value range: 35 ... 85.

Press key  to arrive the next menu item.

### Printer language

Selection of language in which you want to display the text in the printer display.







At the moment the following languages are available: German, English, French, Spanish, Portuguese, Dutch, Italian, Danish, Finnish, Polish, Czech, Hungarian, Russian, Chinese (option), Ukrainian.

Press key  to arrive the next menu item.

### Keyboard layout

Selection of region for the desired keyboard layout.

The following possibilities are available: Germany, England, France, Greece, Spain, Sweden and US.

- Press key  to arrive the next menu item.
- Customized entry**  
**On:** The question referring the customized variable appears once before the print start at the display.  
**Auto:** The question referring the customized variable appears after every printed layouts.  
**Off:** No question appears at the display. In this case the stored default value is printed.
- Press key  to arrive the next menu item.
- Colour processing**  
**On:** The print is effected on both printheads corresponding to the transferred field attributs.  
**Off, print to PH1:** The print is effected at the front printhead.  
**Off, print to PH2:** The print is effected at the rear printhead.  
 At both operating modes the field attributs are ignored and all fields are printed on the set printhead.
- Press key  to arrive the next menu item.
- Backfeed**  
 The backfeed was optimised in the operating modes dispenser (optional) and tear off. Now, when driving into the offset, the following label is 'pre-printed' if possible and therefore the backfeed of label is no necessary and time can be saved.
- Press key  to arrive the next menu item.
- CMI length**  
 If the print is stopped at the rear printhead it could come to a small interruption in the printout. This is shown as a fine white line onto the label. In order to avoid this matter a value for the minimal retraction (0 – 1 mm) can be set. At this value the label material is retracted. At the next print start the free range is overprinted.
- Press key  to arrive the next menu item.
- Password**  
 By a password several functions can be blocked, so the user cannot work with them. There are several applications in which the use of password protection makes sense (see chapter 11.2 Password Protection, page 88).
- Press key  to arrive the next menu item.
- Standard label**  
**On:** If a print order is started without previous definition of label, the standard label is printed.
- POS 108/12 R  
 V1.50 (Build 0001 )  
 NO LABEL DATA
- Off:** If a print order is started without previous definition of label, an error message appears in the display.

**Synchronization at print start**

Press key  to arrive the next menu item.

**Off:** The synchronization is disabled, i.e. the measuring and label feed have to be released manually.

**Measure:** After switching on the printer, the loaded label is automatically measured.

**Feed:** After switching on the printer the label is synchronized to the beginning of label. For this one or multiple labels are advanced.

**7.6 Dispenser I/O (option)**

Switch on the label printer and the display shows the main menu.

Press key  to access the function menu.

Press key  as long as you arrive the *Dispenser I/O* menu.

Press key  to select the menu.

In the upper line of display, the operating mode can be selected.

Press key  to change to the next operating mode.

**Operating modes****Off:**

It is printed without the labels are dispensed.

**I/O static:**

The input signal evaluated, i.e. it is printed as long as the signal exists. The number of labels which was entered at the print start is printed.

The set dispenser offset is not taken into consideration.

**I/O static continuous:**

For description of this operating mode, see *I/O static*.

Continuous means that it is printed as long as new data is transferred via interface

The set dispenser offset is not taken into consideration.

**I/O dynamic:**

The external signal is evaluated dynamically, i.e. is the printer in 'waiting' mode a single label is printed at each signal changing. After the print the set dispenser offset is executed, i.e. a backfeed is effected.

**I/O dynamic continuous:**

For description of this operating mode, see *I/O dynamic*.

Continuous means that it is printed as long as new data is transferred via interface.

**Additional parameters for Dispenser I/O**

After selection of desired Dispenser I/O operating mode, press key  to select additional parameters.

**Dispenser photocell**

First value = Indication of the current sensor level. This indication is for checking purposes and cannot be modified.

Second value = Indication if a label (value = 1) or if no label (value = 0) was found. This indication is for checking purposes if the set switch level leads to a correct label recognition.

Third value = Indication of switch level (Default: 1.2).

Fourth value = Transmission power of label sensor [1..255]  
Depending on label material (color) the sensor level can be adapted in order to permit a safe label recognition (Default: 80).

**NOTICE!**

The modification of this value is only taken into consideration for the operating modes *Photocell* and *Photocell continuous*.

Press key  to arrive the next menu item.

**I/O Port 1-8 and I/O Port 9-16**

Definition of port functions. 2 sign show the current setting for each port.

The first sign specifies the following:

- I** = Port operates as Input
- O** = Port operates as Output
- N** = Port has no function (not defined)

These settings cannot be modified.

The second sign specifies the following:

- +** = Active signal level is 'high' (1)
- = Active signal level is 'low' (0)
- x** = Port is deactivated
- &** = Function is executed at each change of the signal level
- s** = Status can be enquired/influenced\* by interface  
The internal function of print module is deactivated.

The modification of the signal level is only taken into consideration for the operating modes I/O static, I/O dynamic, I/O static continuous and I/O dynamic continuous.





Press key  to arrive the next menu item.

**Debounce**

Indication of debounce time of the dispenser input. The setting range of the debounce time is between 0 and 100 ms.  
In case the start signal is not clear then you can debounce the input by means of this menu item.

---

\* in connection with Netstar PLUS

- Press key  to arrive the next menu item.
- Start signal delay** Indication in time per second of the delay for the start signal.  
Value range: 0.00 to 9.99.
- Press key  to arrive the next menu item.
- I/O protocol** Indication of interface at which the modifications of input signals (I/O) are sent.
- Press key  to arrive the next menu item.
- Save signal** **On:** The start signal for the next label can already be released during printing the current label. The signal is registered from the print module. The print module starts printing the next label immediately after finishing the current one. Therefore time can be saved and performance be increased.  
**Off:** The start signal for the next label can only be released if the current label is printed to the end and the print module is again in 'waiting' state (output 'ready' set). If the start signal was released already before, so this is ignored.
- Press key  to arrive the next menu item.
- I/O Profile** Selection of the available configurations *Std\_Label* (factory setting) or *StdFileSetLabel*.  
The corresponding assignment is indicated on the following page.

**List of registered functions for Std\_Label**

|    |                             |
|----|-----------------------------|
| 1  | Print start (Input)         |
| 2  | No function                 |
| 3  | Counter reset (Input)       |
| 4  | No function                 |
| 5  | Error reset (Input)         |
| 6  | No function                 |
| 7  | No function                 |
| 8  | No function                 |
| 9  | Error (Output)              |
| 10 | Print order active (Output) |
| 11 | No function                 |
| 12 | Printing (Output)           |
| 13 | Ready (Output)              |
| 14 | No function                 |
| 15 | No function                 |
| 16 | Forerun active (Output)     |

**List of registered  
functions for  
StdFileSetLabel**

|    |  |
|----|--|
| 1  | Print start (Input)                      |
| 2  | Error reset (Input)                      |
| 3  | Number of the file to load Bit 0 (Input) |
| 4  | Number of the file to load Bit 1 (Input) |
| 5  | Number of the file to load 2 (Input)     |
| 6  | Number of the file to load 3 (Input)     |
| 7  | Number of the file to load 4 (Input)     |
| 8  | Number of the file to load 5 (Input)     |
| 9  | Error (Output)                           |
| 10 | Print order active (Output)              |
| 11 | No function                              |
| 12 | Printing (Output)                        |
| 13 | Ready (Output)                           |
| 14 | No function                              |
| 15 | No function                              |
| 16 | Forerun active (Output)                  |

## 7.7 Material Savings

Ribbon save = maximum exploitation of transfer ribbon

### Label



### Transfer gibbo w/o ribbon save



### Transfer ribbon with ribbon save

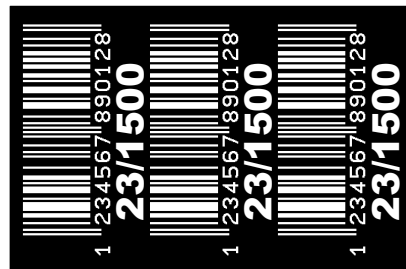

### Procedure

In general, the maximum exploitation of the transfer ribbon is achieved in that the transfer ribbon stops in the event of gaps within the label and/or the distance between two labels and the printhead folds in, i.e. is moved upwards. Thus, the transfer ribbon consumption is reduced.

As can be clearly seen in the example provided above, the transfer ribbon consumption is significantly lower in the 'standard' ribbon save mode.

In the 'Off' ribbon save mode, the printhead is not folded in and, thus, the transfer ribbon consumption is not reduced.





Switch on the label printer and the display shows the main menu.

Press key **F** to access the function menu.

Press key  as long as you arrive the *Ribbon save* menu.

Press key  to select the menu.

Press keys  and  to select the desired ribbon save mode.

### Ribbon save mode

**Off** Optimisation off.

**Standard** Maximum optimisation performance, i.e. there is no transfer ribbon loss whilst this setting is used (except for a safety distance of 1 mm so that the print fields are not printed into one another).  
Settings with which this optimisation can no longer be achieved are not permitted. This applies in particular to offset printing which can now only set in the valid range.

Press key  to arrive the next menu item.

### Label save mode

**Dialog** The printing process is stopped at a suitable position and the printer waits for further data. As soon as this data is transferred to the printer, the printing process continues.

At the end of a print job, the printer remains in the above position so that a follow-up print job can be transferred to the printer without any loss of material.

Press the  key to stop the print job. In doing so, the remaining labels of the print job are completed.

Blank labels are fed into the printer until the last completed label has passed the front printhead.

**Auto** After an adjustable time which can be set under the menu item *Auto feed delay*, the remaining labels between the two printheads are printed.

**Off** The print is only stopped after complete printing of all labels. Slow data connections or labels with a long generating time can lead to a loss of material. In the dispensing modes is this mode activated automatically.

**Auto feed delay**

Press key  to arrive the next menu item.

Setting of time after that the remaining labels between the printheads were automatically printed.

Value range 0 ... 255 seconds

## 7.8 Network

Switch on the label printer and the display shows the main menu.

Press key  to access the function menu.

Press key  as long as you arrive the *Network* menu.

Press key  to select the menu.

For more information, please see the separate manual.

## 7.9 Remote console

Switch on the label printer and the display shows the main menu.

Press key  to access the function menu.

Press key  as long as you arrive the *Remote console* menu.

Press key  to select the menu.

For more information please contact our sales department.

## 7.10 Interface

Switch on the label printer and the display shows the main menu.

Press key  to access the function menu.

Press key  as long as you arrive the *Interface* menu.

Press key  to select the menu.

### COM1 / Baud / P / D / S

#### COM1:

0 - serial interface Off.

1 - serial interface On.

2 - serial Interface On, no error message occurs in case of a transmission error.

#### Baud:

Indication of bits which are transferred per second (speed of data transfer).

Value range: 1200, 2400, 4800, 9600, 19200, 38400, 57600 and 115200.

#### P = Parity:

N - No parity

E - Even

O - Odd

Please observe that the settings correspond to those of the printer.

#### D = Data bits:

Setting of data bits.

Value range: 7 or 8 Bits.

#### S = Stop bits:

Indication of stop bits between bytes.

Value range: 1 or 2 stop bits.

Press key  to arrive the next menu item.

### Start sign / End sign

**SOH:** Start of data transfer block → Hex format 01



**ETB:** End of data transfer block → Hex format 17

Two different start / en signs can be set. The settings are normally SOH = 01 HEX and ETB = 17 HEX. Several host computers cannot process these signs and therefore SOH = 5E HEX and ETB = 5F cannot be set.

Press key  to arrive the next menu item.

### Port test

Check whether the data are transferred via the interface.

Press the  and  keys to select standard (on). Press the  key and the data sent via any port (COM1, LPT, USB, TCP/IP) is printed.

## 7.11 Date & Time





Switch on the label printer and the display shows the main menu.

Press key **F** to access the function menu.

Press key  as long as you arrive the *Date/Time* menu.

Press key  to select the menu.

### Setting of date and time

The upper line of display shows the current date, the second line the current time. Press keys  to  arrive the next input field. Press keys  and  to increase and/or decrease the figures at the cursor position.

Press key  to arrive the next menu item.

### Summertime

**On:** Printer automatically adjust clock for daylight saving changes.

**Off:** Summertime is not automatically recognized and adjusted.

Press key  to arrive the next menu item.

### Start of summertime – Format

Select the format in which you want to define beginning summertime. The above example indicates the default setting (European format).

|            |           |  |
|------------|-----------|--|
| DD = day   | WW = week | WD = weekday   |
| MM = month | YY = year | next day = only next day is taken into consideration |

Press key  to arrive the next menu item.

### Start of summertime – Date

By means of this function you can enter the date at which summertime has to start. This entry refers to the previously selected format. Example: summertime is automatically adjusted at last Sunday in March (03).

Press key  to arrive the next menu item.

### Start of summertime – Time

By means of this function you can define the time when you want to start summertime.

Press key  to arrive the next menu item.

### End of summertime – Format

Select the format in which you want to define end of summertime. The example above indicates the default setting (European format).

Press key  to arrive the next menu item.

### End of summertime – Date

By means of this function you can define the date when you want to stop summertime. The entry refers to the previously selected format. Example: summertime is automatically adjusted at last Sunday in October (10).

Press key  to arrive the next menu item.

### End of summertime – Time

By means of this function you can define the time when you want to stop summertime.

Press key  to arrive the next menu item.

### Time shifting

By means of this function you can enter time shifting in hours and minutes (for automatically adjustment from summer and wintertime). This entry refers to the currently set printer time.

## 7.12 Service Functions



### NOTICE!

So that the distributor res. the manufacturer in case of service can offer fast support the necessary information such as selected parameters can be taken directly from the service functions menu of the device.

Switch on the label printer and the display shows the main menu.

Press key to access the function menu.

Press key as long as you arrive the *Service functions* menu.

Press key to select the menu.

### Label parameters

Indication of label parameters in Volt.

**A:** Indication of minimum value.

**B:** Indication of difference between minimum and maximum value.

**C:** Indication of trigger level. The value is ascertained while measuring and can be changed.

Press key to arrive the next menu item.

### Photocell configuration (front printhead)

Indication of photocell level of the front printhead.

In case of problems while positioning or measuring of label, levels for label photocell can be set manually. Make sure that a large hub as possible (above the label >3 V, above the gap <1 V) is set.

Press key to arrive the next menu item.

### Photocell configuration (rear printhead)

Indication of photocell level of the rear printhead.

In case of problems while positioning or measuring of label, levels for label photocell can be set manually. Make sure that a large hub as possible (above the label >3 V, above the gap <1 V) is set.

Press key to arrive the next menu item.

### Photocell parameters

**PC1:** Indication of label photocell level of the front photocell in Volt.

**PC2:** Indication of label photocell level of the rear printhead in Volt.

**OPC:** Indication of ribbon save photocell level in Volt.

**TR:** Indication of transfer ribbon photocell status  
(either 0 or 1).

The first value stands for the front photocell and the second value for the rear photocell.

**H:** Indication of printhead position.

0 = printhead down

1 = printhead up

The first value stands for the front photocell and the second value for the rear photocell.

Press key  to arrive the next menu item.

### Setting mode

#### Setting Mode ON:

The Printheads can be adjusted more easily.

The following parameters are set automatically: continuous labels, label size = 50 mm. These settings can be changed manually.

The following control functions are deactivated: 'printhead open' control, transfer ribbon control, label photocell Off (continuous labels).



#### CAUTION!

Switching off the control functions can lead to uncontrolled operation of the printer.

⇒ The setting mode is only to use for adjusting the printheads.

#### Setting Mode OFF:

When switching Off the printer, the setting mode is automatically deactivated.

Press key  to arrive the next menu item.

### Paper counter

**D:** Indication of printhead attainment in meters.

**G:** Indication of printer attainment in meters.

Press key  to arrive the next menu item.

### Heater resistance

To achieve a high print quality, the indicated Ohm value must be set after an exchange of printhead.

The heater resistance value can be set for both printheads.

Press key  to arrive the next menu item.

### Printhead temperature

Indication of printhead temperature. The printhead temperature corresponds normally to the room temperature. In case the maximum printhead temperature is exceeded, the current print order is interrupted and an error message appears at the printer display. The printhead temperature is displayed for both printheads.

Press key  to arrive the next menu item.

### Printhead 2 Offset

For setting the automatic offset for the rear printhead in order to optimise the print image.

**X-adjustment:** Adjusting the position of the print image of the rear printhead (colour component) transversely to the direction of paper movement.

**Y-adjustment:** Adjusting the position of the print image of the rear printhead in the direction of paper movement.

Any changes to these parameters alter the relative adjustment of the print contents of the front and rear printheads.

Press key  to arrive the next menu item.

### Motor Ramp

This function is often used for high printing speed as the tearing of transfer ribbon can be prevented.

The higher the '++' value is set, the slower the feeding motor is accelerated.

The smaller the '--' value is set, the faster the feeding motor is decelerated.

Press key  to arrive the next menu item.

### Print examples

**Settings:** Printout of all printer settings such as speed, label and transfer ribbon material.

**Bar codes:** Printout of all available bar code types.

**Fonts:** Printout of all available font types.

Press key  to arrive the next menu item.

### Input

Indication of input signal level.

0 = Low

1 = High

| Port | Function                                     |
|------|--|
| 1    | = Print start                                |
| 2    | = Cut  |
| 3    | = Counter Reset                              |
| 4    | = External synchronisation of label position |
| 5    | = No function                                |
| 6    | = No function                                |
| 7    | = No function                                |
| 8    | = No function                                |

Press key  to arrive the next menu item.

### Output

Indication of output signal level

0 = Low

1 = High

| Port | Function             |
|------|----------------------|
| 9    | = Error              |
| 10   | = Print order active |
| 11   | = No function        |
| 12   | = Print end          |
| 13   | = Ready              |
| 14   | = No function        |
| 15   | = No function        |
| 16   | = Forerun active     |

**I/O Status**

Press key  to arrive the next menu item.

Relevant results are counted and registered in RAM memory. The protocols get lost after switching off the device.

**RInt** = Real Interrupts

The start input impulses are counted directly at the Interrupt.

**Dbnc** = Debounced

The start input impulses that are longer than the set debounce time are counted. Only these start impulses can lead to a print. If a start impulse is too short, no print is released. This is recognized by the fact that RInt is counted, Dbnc not.

**NPrn** = Not Printed

The debounced start input impulses that have not lead to a print are counted. Causes: no active print order, print order stopped (manually or because of an error) or the printing system is still active with the processing of a print order.

**PrtStrtReset** = The counters are reset.

**PrtStrtTime** = Measured length of the last start impulse in ms.

Press key  to arrive the next menu item.

**Online / Offline**

This function is activated e.g. if the transfer ribbon is to be changed. It is avoided that a print order is processed although the module is not ready. If the function is activated then press the key  to change between Online and Offline mode. The respective state is indicated in the display.

Standard: Off

**Online:** Data can be received by interface. The keys of the foil keyboard are only active, if you changed in the Offline mode with key .

**Offline:** The keys of the foil keyboard are still active but received data are not processed. If the module is again in Online mode then new print orders can be again received.

Press key  to arrive the next menu item.

**Zero point adjustment in Y direction**

Indication of value in 1/100 mm.

After replacing the printhead - the print cannot be continued at the same position on the label, the difference can be corrected in printing direction.

**NOTICE!**

The value for zero point adjustment is set ex works. After replacing the printhead, only service personnel are allowed to set this value anew.

Press key  to arrive the next menu item.

**Zero point adjustment in X direction**



Indication of value in 1/100 mm.

After replacing the printhead - the print cannot be continued at the same position on the label, the difference can be corrected across the printing direction.

**NOTICE!**

The value for zero point adjustment is set ex works. After replacing the printhead, only service personnel are allowed to set this value anew.



- Press key  to arrive the next menu item.
- Print length +/-**  
Indication of print layout correction in percent.  
By mechanical influences (e.g. label roll size) the print layout can be printed increased and reduced to its original size.  
Value range: +10.0% ... -10.0%
- Press key  to arrive the next menu item.
- Internal**  
For internal use only.

### 7.13 Main menu

Switch on the label printer and the display shows the main menu. The main menu shows information such as printer type, current date and time, version number of firmware and the used FPGA.

The selected display is shown for a short time, then the indication returns to the first information.

Press key  to arrive the next information display.



## 8 Compact Flash Card / USB Memory Stick

### 8.1 General Information

On the back side of the label printer is the slot for the CF card and the USB port for inserting the USB memory stick.

The mass storage menu (memory menu) permits the access to CF cards or USB memory sticks attached to the printer. Among loading and saving labels simple operations of contents are possible such as delete files/directories, copy files/directories or formatting.



#### NOTICE!

In case of a malfunction of the original memory medium it is recommend to copy the most important data by means of a commercial Card Reader.

### 8.2 Display Structure

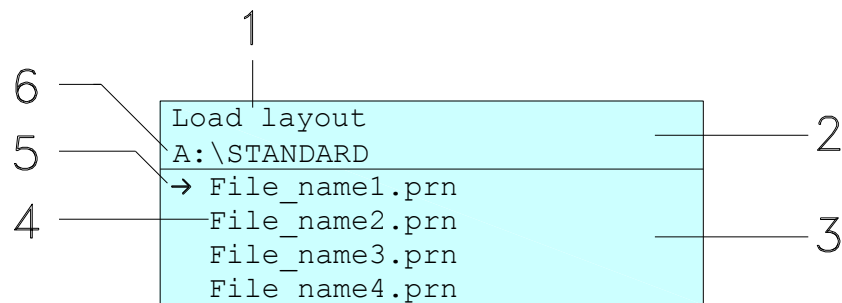

1 = Current function

2 = 2-lined header

3 = Scroll range

4 = File names / directory names

5 = Marking of the selected file (cursor)

6 = Current path (drive:\directory)

The two-line header (2) contains the current function name (1) and the current path (6).

The four-line scroll range indicates a list of files/directories. The first entry (marked with an arrow) is the active one. To this file/directory and/or these files/directories refer all actions.



#### NOTICE!

Three drives are available.

A:\ indicates the CF card.



















U:\ indicates the USB memory stick.

(only one stick can be inserted)

R:\ indicates the RAM (ZPL Emulation).

### 8.3 Navigation

The memory menu is operated with the keys of the foil keyboard of the control unit or with different function keys of an attached USB keyboard.

|   |   |  |
|---|---|--|
|    |    | Return to the previous menu.   |
|    |    | Function <i>Load layout</i> : Change to the File Explorer.<br>File Explorer: Change to the 'context menu'. |
|    |    | Select a file/directory if a multiple selection is possible.   |
|    |    | Main menu: Access to the memory menu.<br>File Explorer: Create a new file.                                 |
|    |    | Start the current function for the active file/directory.  |
|    |    | Change to the superordinate directory.   |
|   |   | Change to the currently marked directory.  |
|  |  | In the current directory scroll upwards.   |
|  |  | In the current directory scroll downwards.   |

## 8.4 Define User Directory



### NOTICE!

An user directory is to be defined:

- before using and/or navigating through the memory menu.
- if formatting of CF card is effected at PC and thus the STANDARD directory was not created automatically.

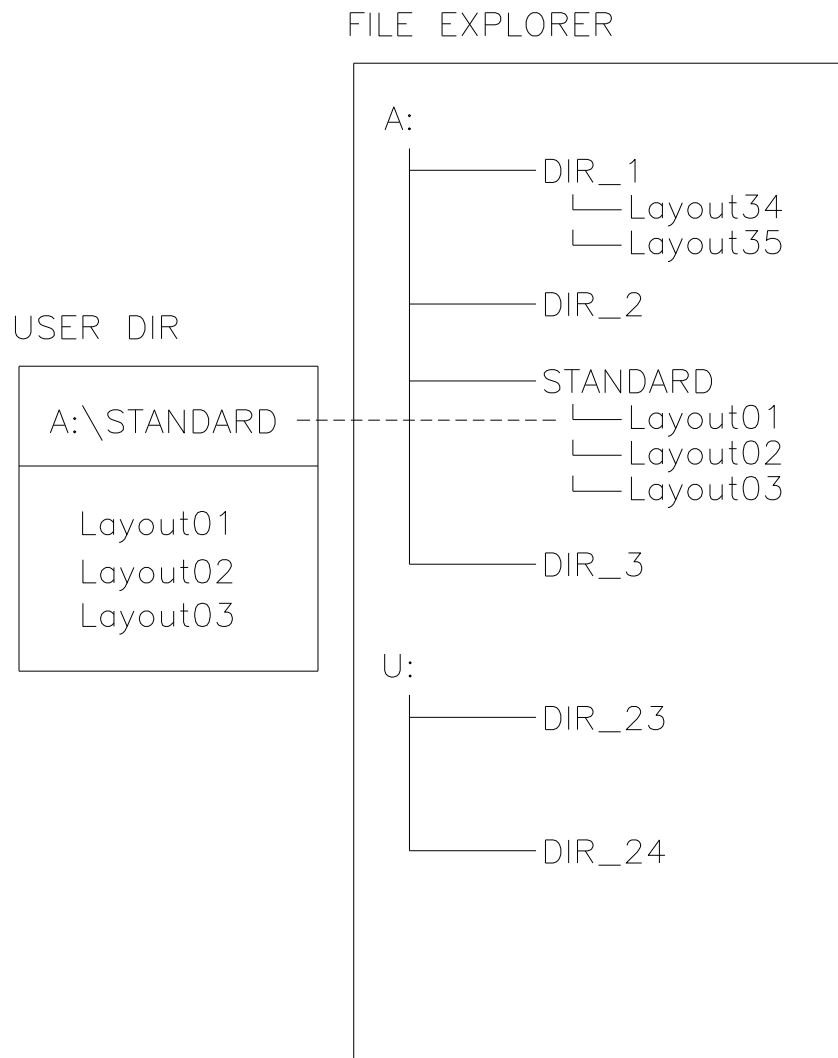

The user directory is the root directory in which the user saves usually the most frequently used files/layouts. The utilisation of the user directory permits the quick and direct access to the files saved in the defined user directory. The definition of an user directory saves thus a long search of the file to be printed.

Press key  to access to the memory menu.

Press key  to call the File Explorer.

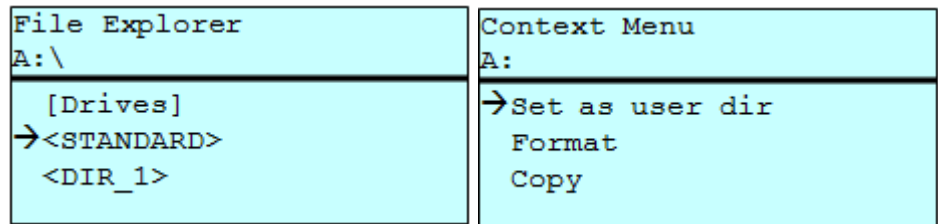

Press keys , , ,  to select the directory.

Press key  to display all available functions.

Select the function *Set as user dir* and press key  to confirm the selection.

Press key  as long as the printer returned to the main menu.



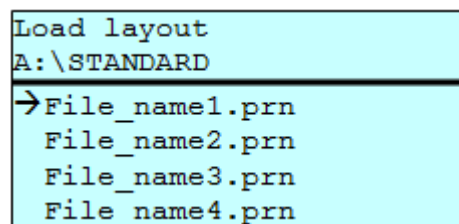

At the next start of the memory menu the selected directory is displayed as user directory.

## 8.5 Load Layout

Loads a layout within a defined user directory. The function allows quick access to the desired layout as only layout files are displayed and directories hidden.



Press key  to access to the memory menu.

Press keys , , ,  to select the layout to be printed.

Press key  to confirm the selection.

The printer display shows automatically the window to insert the number of copies which are to print.

Select the number of copies which are to be printed.

Press key  to start the print order.



### NOTICE!

The directory CANNOT be changed here. A change of directory MUST be made in the File Explorer with the function *Change directory*.

## 8.6 File Explorer

The File Explorer is the file manager of the printing system. The File Explorer provides the main functions for the user interface of memory menu.

In the user directory, press key **F** to access to the File Explorer.

Following functions are available:

- Change drive and/or directory
- Load file
- Save layout and/or configuration
- Delete file(s)
- Format CF card
- Copy file(s)

### Change drive/directory

Selection of drive and/or directory in which the files are saved.

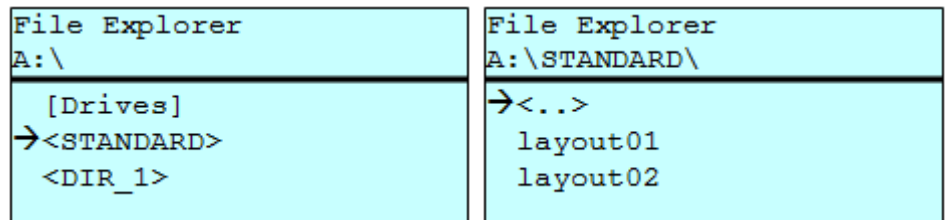

Press key **M** to access to the memory menu.

Press key **F** to call the File Explorer.

Press keys **▲**, **▼**, **◀**, **▶** to select the directory.

Press key **●** to confirm the selection.

The selected directory is now displayed.

**Load file**

Loads a file. This can be a configuration saved before, a layout, etc.

```
Load file
A:\STANDARD\
<..>
→ layout01
  layout02
```

Press key  to access to the memory menu.

Press key  to call the File Explorer.

Press keys  and  to select the file.

Press key  to load the selected file.

If the selected file is a layout, then the number of copies to print can be entered immediately.

**Save layout**

Saves the currently loaded layout under the selected name.

```
Save file
A:\STANDARD
→ Save layout
  Save config.
  noname
```

Press key  to access to the memory menu.

Press key  to call the File Explorer.

Press key  to change to the menu *Save file*.

Select the function *Save layout* and confirm the selection with key .

If an USB keyboard is attached a new file name for *noname* can be assigned.



**Save configuration**

Saves the complete, current printer configuration under the selected name.

```
Save file
A:\STANDARD
-----
Save layout
→ Save config.
-----
config.cfg
```

Press key  to access to the memory menu.

Press key  to call the File Explorer.

Press key  to change to the menu *Save file*.

Select the function *Save configuration* and confirm the selection with key .

If an USB keyboard is attached a new file name for *config.cfg* can be assigned.

**Delete file(s)**

Deletes one or more files and/or directories irrevocably. With the deletion of a directory both the contained files and the subdirectories are deleted.

|  |  |
|--|--|
| File Explorer<br>A:\STANDARD\<br>-----<br>layout01 * | Context menu<br>2 objects marked<br>-----<br>→ Delete<br>Copying |
| → layout02 *   |  |
| layout03   |  |
| layout04   |  |

Press key  to access to the memory menu.

Press key  to call the File Explorer.

Press keys  and  to select the file.

Press key  to mark the files which are to be deleted. The marked entries are listed with \*. Repeat this procedure until all desired files and/or directories are marked for deletion.

Press key  to call the context menu.

Select the function *Delete* and confirm the selection with key .

**NOTICE!**

The deleting procedure is irreversible!

**Formatting**

Formats irrevocably the memory card.

**NOTICE!**

USB sticks cannot be formatted at the printer!

|  |   |
|--|---|
| File Explorer<br>DRIVES<br>→A: 954Mb free<br>U: No media | Context menu<br>A:\<br>Set as user dir<br>→Formatting<br>Copy |
|--|---|

Press key  to access to the memory menu.

Press key  to call the File Explorer.

Select the drive which is to format with the navigation keys.

Press key  to call the context menu.

Select the function *Format* and confirm the selection with key .

**Copying**

Creates a duplicate of the original file and/or the original directory to make changes independently of the original.

|   |   |
|---|---|
| File Explorer<br>A:\STANDARD\<br>layout01 *<br>→ layout02 *<br>layout03<br>layout04 | Context menu<br>2 objects marked<br>Delete<br>→ Copying |
|---|---|

Press key  to access to the memory menu.

Press key  to call the File Explorer.

Press keys  and  to select the file.

Press key  to mark the files which are to be copied. The marked entries are listed with \*. Repeat this procedure until all desired files and/or directories are marked for copying.

Press key  to call the context menu.

Select the function *Copy* and confirm the selection with key .

|   |
|---|
| Select Destination<br>DRIVES<br>→ A: 954Mb free |
|---|

Select the target storage with the navigation keys and press key  to confirm the selection.

## 8.7 Firmware Update

Starting from firmware version 1.58 it is possible to make a firmware update also via the memory menu. Both the USB stick as well as the CF card can be used for this.

### Procedure

On the CF card / USB memory stick a directory is created in which the necessary update files are stored (firmware.prn, data.prn). By means of the function *Load file* the file *firmware.prn* is selected/loaded. In the first step the printer executes the firmware update. After the necessary restart automatically the file *data.prn* is loaded. In this way the remaining components were updated. is After a renewed restart the update procedure is finished.

## 8.8 Filter

For certain functions a filter mask or a file name of a file which is to be saved can be entered. This input is indicated in the path line. It is possible with the filter mask to look for certain files. For example, with the input of 'L' only the files are listed whose character string starts with 'L' (regardless of upper and lower cases).

### Without filter

```
Load layout
A:\STANDARD
→First_file.prn
  Layout_new.prn
  Sample.prn
  12807765.prn
```

### With filter

```
Load layout
L
→Layout_new.prn
```

## 9 Maintenance and Cleaning



### DANGER!

Risk of death by electric shock!

⇒ Disconnect the label printer from power supply before performing any maintenance work.



### NOTICE!

When cleaning the label printer, personal protective equipment such as safety goggles and gloves are recommended.

### Maintenance schedule

| Maintenance task  | Frequency  |
|---|--|
| General cleaning (see section 9.1, page 70).                        | As necessary.  |
| Cleaning transfer ribbon drawing roller (see section 9.2, page 70). | Each time the transfer ribbon is changed or when the printout is adversely affected.                 |
| Cleaning printer roller (see section 9.3, page 70).                 | Each time the label roll is changed or when the printout and label transport are adversely affected. |
| Cleaning printhead (see section 9.4, page 72).                      | Each time the transfer ribbon is changed or when the printout is adversely affected.                 |
| Cleaning label photocell (see section 9.5, page 73).                | When exchanging the label roll.  |
| Replacing printhead (see section 9.6, page 74).                     | In case of errors in printout.   |



### NOTICE!

The handling instructions for the use of Isopropanol (IPA) must be observed. In the case of skin or eye contact, immediately wash off the fluid thoroughly with running water. If the irritation persists, consult a doctor. Ensure good ventilation.



### WARNING!

Risk of fire by easily inflammable label soluble!

⇒ When using label soluble, dust must be completely removed from the label printer and cleaned.

## 9.1 General Cleaning



### CAUTION!

Abrasive cleaning agents can damage the label printer!

- ⇒ Do not use abrasives or solvents to clean the outer surface of the label printer.
- ⇒ Remove dust and paper fuzz in the printing area with a soft brush or vacuum cleaner.
- ⇒ Clean outer surfaces with an all-purpose cleaner.

## 9.2 Cleaning the Transfer Ribbon Drawing Roller

A soiled print roll can lead to reduced print quality and can affect transport of material.

1. Open printer cover.
2. Remove transfer ribbon from the label printer.
3. Remove deposits with roller cleaner and a soft cloth.
4. If the roller appears damaged, replace it.

## 9.3 Cleaning the Printer Roller

A soiled print roll can lead to reduced print quality and can affect transport of material.



### CAUTION!

Printhead can be damaged!

- ⇒ Do not use sharp or hard objects to clean the printer roller.

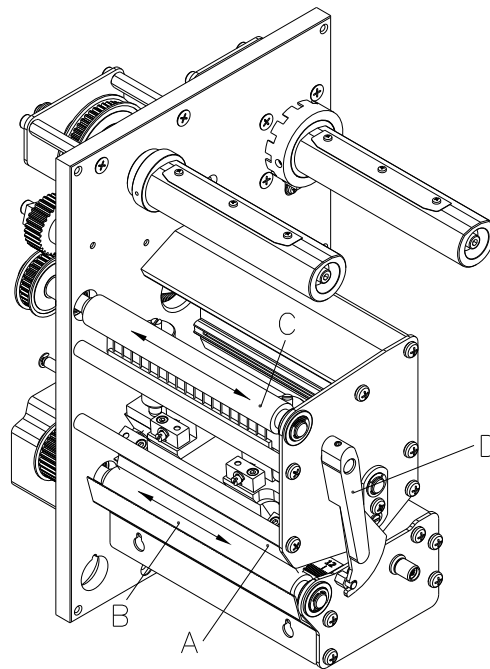

**Figure 11**

1. Open printer cover.
2. Turn red lever (D) counter clockwise to lift up the printhead (A).
3. Remove labels and transfer ribbon from the label printer.
4. Remove deposits with roller cleaner and a soft cloth.
5. Turn the roller (B + C) manually step by step to clean the complete roller (only possible when printer is switched off, as otherwise the step motor is full of power and the roller is kept in its position).

## 9.4 Cleaning the Printhead

Printing can cause accumulation of dirt at printhead e.g. by colour particles of transfer ribbon, and therefore it is necessary to clean the printhead in regular periods depending on operating hours, environmental effects such as dust etc.



### CAUTION!

Printhead can be damaged!

- ⇒ Do not use sharp or hard objects to clean the printhead.
- ⇒ Do not touch protective glass layer of the printhead.

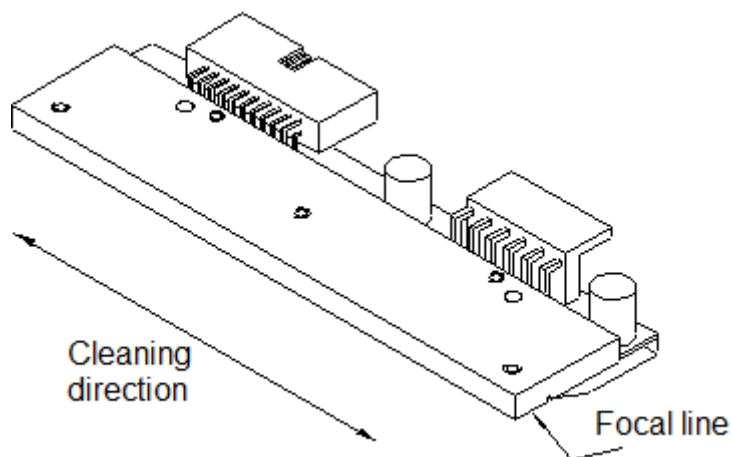

**Figure 12**

1. Open printer cover.
2. Turn red lever (D, in Figure 11) anticlockwise to lift up the printhead.
3. Remove labels and transfer ribbon from the label printer.
4. Clean printhead surface with special cleaning pen or a cotton swab dipped in pure alcohol.
5. Allow printhead to dry for 2-3 minutes before commissioning the printer.



## 9.5 Cleaning the Label Photocell



### CAUTION!

Label photocell can be damaged!

⇒ Do not use sharp or hard objects or solvents to clean the label photocell.

The label photocell can become dirtied with paper dust and this can adversely affect label detection.

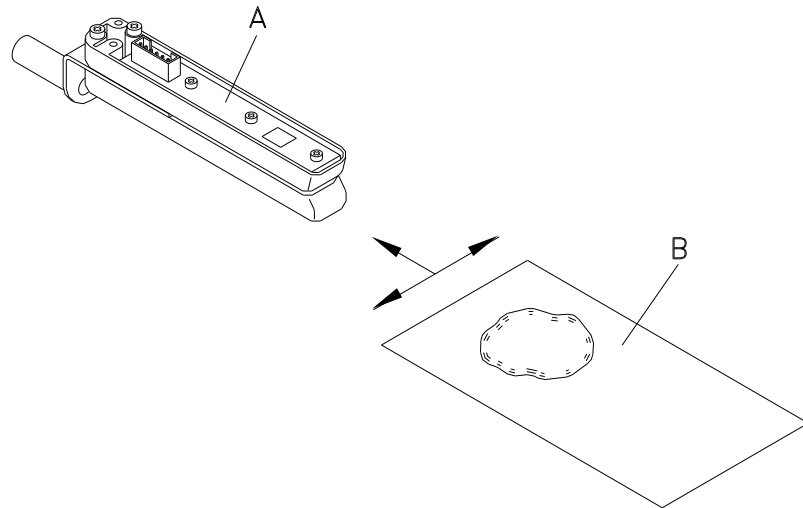

**Figure 13**

1. Open printer cover.
2. Turn red lever anticlockwise to lift up the printhead.
3. Remove labels and transfer ribbon from the label printer.
4. Blow out the photocell (A) with pressure gas spray. Observe strictly the instructions on the spray can!
5. Clean the label photocell (A) additionally with a cleaning card (B) before soaked in pure alcohol. Move the cleaning card from one side to the other (see illustration).
6. Reload the labels and transfer ribbon (see chapter 6 Loading Media, page 31).

## 9.6 Replacing the Printhead



### CAUTION!

The printhead can be damaged by static electricity discharges and impacts!

- ⇒ Set up the device on a grounded, conductive surface.
- ⇒ Ground your body, e.g. by wearing a grounded wristband.
- ⇒ Do not touch contacts on the plug connections.
- ⇒ Do not touch the printhead with hard objects or your hands.

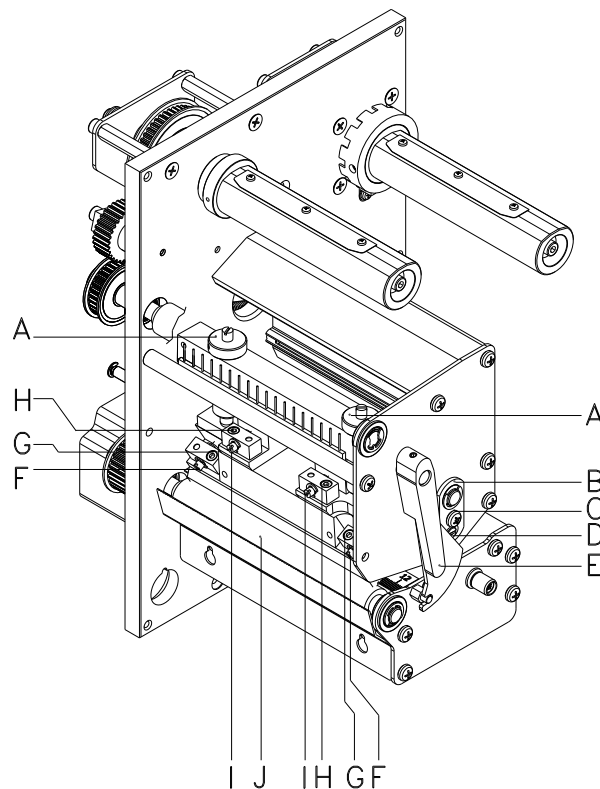

**Figure 14**

### Removing the printhead

1. Open the printer cover.
2. Remove labels and transfer ribbon from the label printer.
3. When printhead is closed, loosen the fixing screws (G).
4. Remove the label guiding between the printheads.
5. Turn red lever (E) anticlockwise to lift up the printhead.
6. If the printhead (5) is not disengaged on the pressure roller (J), continue loosen the fixing screws (G).
7. Remove the printhead carefully to the front until you can reach the plug connections.
8. Remove plug connections and then remove printhead.

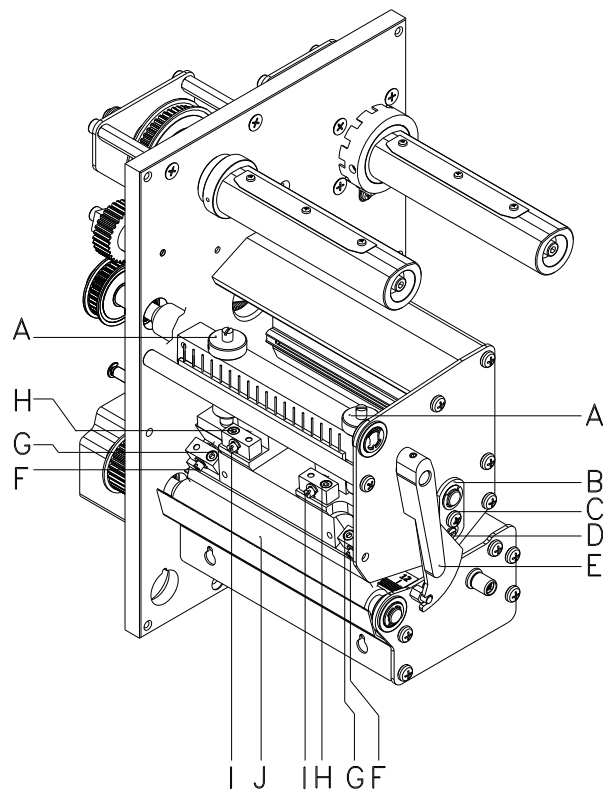

**Figure 15**

### Installing the printhead

1. Attach plug connections.
2. Position printhead in printhead mounting bracket in such a way that the pins are secured in the corresponding holes in the head plate.
3. Lightly keep printhead mounting bracket on the printer roller with one finger and check for correct positioning of the printhead.
4. Screw in fixing screws (G) and tighten it.
5. Install again the label guiding.
6. Reload labels and transfer ribbon (see chapter 6 Loading Media, page 31).
7. Check resistance value on the type plate of printhead and if necessary change the value in the menu *Service functions/Heater resistance*.

## 9.7 Adjusting the Printhead

### Parallelism

An important characteristic for a high quality print is the parallelism of the focal line of the thermal printhead to the pressure roll. Because of the fact that the position of focal line of the printhead depends on fluctuations caused by production, it is necessary to adjust the parallelism.

The form of the CornerType printhead needs the setting of parallelism in direction of the adjusting angle and in horizontal position. It needs a little bit of experience to know in which direction you have to adjust the printhead to receive a high quality printing.

1. Loosen the screws (G oder H, Figure 15) with a hexagon key by approx.  $\frac{1}{4}$  rotations.
2. Adjust the parallelism with the adjusting screws (E or I, Figure 15).  
Clockwise = printhead moves backwards  
Counter clockwise = printhead moves forwards
3. Adjust the parallelism as long as the printing result comes up to your full expectation.
4. Tighten again screws (G or H, Figure 15).
5. Start a print order with approx. 10 labels and control the correct passage of transfer ribbon.

### Pressure balance right/left

After adjusting parallelism and no even strong pressure exists over the complete print width, by means of a plate (6) you can set the balance as follows:

1. Loosen screw (C, Figure 15) with a screwdriver by approx.  $\frac{1}{4}$  rotations.
2. In order to achieve a pressure balance, turn the excentric bolt (D, Figure 15) as long as the printing result comes up to your full expectation.
3. Tighten again screw (C, Figure 15).
4. Start a print order with approx. 10 labels and control the correct passage of transfer ribbon.

**Pressure**

Increasing the printhead contact pressure leads to an improvement of the print image density on the corresponding side and to a shifting of the ribbon feed path in the corresponding direction.

**CAUTION!**

Damage of printhead by unequal use!

⇒ Change factory settings only in exceptional cases.

The selection of the smallest value can optimise the life cycle of printhead.

1. Turn pressure screws (A, Figure 15) to change the pressure of printhead.
2. Turning the pressure screws (A, Figure 15) as far as they will go in clockwise direction results in a pressure increase of 10N in contrast to the factory setting.
3. Turning the pressure screws (A, Figure 15) exactly one rotation from the right stop position counter clockwise results in the factory settings.

**NOTICE!**

It is importantly that the knurled button which is coated with protective lacquer is not removed from the pressure screw as otherwise the above mentioned settings are faulty.



## 10 Error correction

| Error message       | Cause   | Remedy  |
|---------------------|---|---|
| 1 Line too high     | Line rises up completely or partly over the upper edge of label.  | Move line down (increase Y value).<br>Check rotation and font.                                  |
| 2 Line too low      | Line rises up completely or partly over the bottom edge of label.   | Move line up (reduce X value).<br>Check rotation and font.                                      |
| 3 Character set     | One res. several characters of the text is res. are not available in the selected font.   | Change text.<br>Change font.  |
| 4 Unknown code type | Selected code is not available.   | Check code type.  |
| 5 Unvalid position  | Selected position is not available.   | Check position.   |
| 6 CV font           | Selected font is not available.   | Check font.   |
| 7 Vector font       | Selected font is not available.   | Check font.   |
| 8 Measuring label   | While measuring no label was found.<br>Set label length is too large.   | Check label length and if labels are inserted correctly.<br>Restart measuring anew.             |
| 9 No label found    | No label available.<br>Soiled label photocell.<br>Labels not inserted correctly.  | Insert new label roll.<br>Check if labels are inserted correctly.<br>Clean the label photocell. |
| 10 No ribbon        | During the print order the ribbon roll becomes empty (front printhead).<br>Defect at the transfer ribbon photocell (front photocell). | Change transfer ribbon.<br>Check transfer ribbon photocell (service functions).                 |
| 11 COM FRAMING      | Stop bit error.   | Check stop bits.<br>Check baud rate.<br>Check cable (printer and PC).                           |
| 12 COM PARITY       | Parity error.   | Check parity.<br>Check baud rate.<br>Check cable (printer and PC).                              |
| 13 COM OVERRUN      | Loss of data at serial interface (RS-232).  | Check baud rate.<br>Check cable (printer and PC).   |

| <b>Error message</b>        | <b>Cause</b>  | <b>Remedy</b>   |
|-----------------------------|---|---|
| 14 Field numer              | Received line number is invalid at RS-232 and Centronics.                                 | Check sent data.<br>Check connection PC - printer.        |
| 15 Length mask              | Invalid length of received mask statement.  | Check sent data.<br>Check connection PC - printer.        |
| 16 Unknown mask             | Transferred mask statement is invalid.  | Check sent data.<br>Check connection PC - printer.        |
| 17 Missing ETB              | No end of data found.   | Check sent data.<br>Check connection PC - printer.        |
| 18 Invalid character        | One res. several characters of the text is res. are not available in the selected font.   | Change text.<br>Change font.                              |
| 19 Invalid statement        | Unknown transferred data record.  | Check sent data.<br>Check connection PC - printer.        |
| 20 Invalid check digit      | For check digit control the entered res. received check digit is wrong.                   | Calculate check digit anew.<br>Check code data.           |
| 21 Invalid SC number        | Selected SC factor is invalid for EAN res. UPC.   | Check SC factor.  |
| 22 Invalid number of digits | Entered digits for EAN res. UPC are invalid<br>< 12; > 13.                                | Check number of digits.                                   |
| 23 Check digit calculation  | Selected check digit calculation is not available in the bar code.                        | Check calculation of check digit.<br>Check bar code type. |
| 24 Invalid extension        | Selected zoom factor is not available.  | Check zoom factor.  |
| 25 Offset sign              | Entered sign is not available.  | Check offset value.                                       |
| 26 Offset value             | Entered offset value is invalid.  | Check offset value.                                       |
| 27 Printhead temperature    | Printhead temperature is too high.<br>Defective printhead sensing device.                 | Reduce contrast.<br>Change printhead.                     |
| 28 Cutter error             | With cut an error occurred.<br>Paper jam.   | Check label run.<br>Check cutter run.                     |
| 29 Invalid parameter        | Entered data do not correspond to the characters allowed from the application identifier. | Check code data.  |



| <b>Error message</b>        | <b>Cause</b>   | <b>Remedy</b>   |
|-----------------------------|--|---|
| 30 Application Identifier   | Selected application identifier is not available in GS1-128.                     | Check code data.  |
| 31 HIBC definition          | F Missing HIBC system sign.<br>Missing primary code.                             | Check definition of HIBC code.  |
| 32 System clock             | Real Time Clock function is selected but the battery is empty.<br>Defective RTC. | Change battery.<br>Change RTC component.                              |
| 33 No CF interface          | Interrupted connection CPU - CF card.<br>Defective CF card interface.            | Check connection CPU - CF card interface.<br>Check CF card interface. |
| 34 No print memory          | No print CF found.   | Check CF assembly on CPU.   |
| 35 Cover open               | At start of a print order the printhead is open.                                 | Close the printhead and start print order anew.                       |
| 36 BCD invalid format       | BCD error<br>Invalid format for the calculation of Euro variable.                | Check entered format.   |
| 37 BCD overflow             | BCD error<br>Invalid format for the calculation of Euro variable.                | Check entered format.   |
| 38 BCD division             | BCD error<br>Invalid format for the calculation of Euro variable.                | Check entered format.   |
| 39 FLASH ERROR              | Flash component error.   | Run a software update.<br>Change CPU.                                 |
| 40 Length command           | Invalid length of the received command statement.                                | Check data sent.<br>Check connection PC - printer.                    |
| 41 No drive                 | CF card not found / not correctly inserted.                                      | Insert CF card correctly.   |
| 42 Drive error              | Impossible to read CF card (faulty).   | Check CF card, if necessary change it.                                |
| 43 Not formatted            | CF Card not formatted.   | Format CF card.   |
| 44 Delete current directory | Attempt to delete the actual directory.  | Change directory.   |
| 45 Path too long            | Too long indication of path.   | Indicate a shorter path.  |

| <b>Error message</b>     | <b>Cause</b>  | <b>Remedy</b>   |
|--------------------------|---|---|
| 46 Drive write-protected | Memory card is write-protected.   | Deactivate write protection.  |
| 47 Directory not file    | Attempt to indicate a directory as file name.                                 | Correct your entry.   |
| 48 File already open     | Attempt to change a file during an access is active.                          | Select another file.  |
| 49 No file/directory     | File does not exist on CF card.   | Check file name.  |
| 50 Invalid file name     | File name contains invalid characters.  | Correct entry of name, remove special characters.                   |
| 51 Internal file error   | Internal file system error.   | Please contact your distributor.                                    |
| 52 Root full             | The max. number (64) of main directory entries is reached.                    | Delete at least one main directory entry and create subdirectories. |
| 53 Drive full            | Maximum CF capacity is reached.   | Use new CF Card, delete no longer required files.                   |
| 54 File/directory exists | The selected file/directory already exists.                                   | Check name, select a different name.                                |
| 55 File too large        | During copying procedure not enough memory space onto target drive available. | Use a larger target card.   |
| 56 No update file        | Errors in update file of firmware.  | Start update file anew.   |
| 57 Invalid graphic file  | The selected file does not contain graphic data.                              | Check file name.  |
| 58 Directory not empty   | Attempt to delete a not empty directory.                                      | Delete all files and sub-directories in the desired directory.      |
| 59 No interface          | No CF card drive found.   | Check connection of CF card drive.<br>Contact your distributor      |
| 60 No CF card            | No CF card is inserted.   | Insert CF card in the slot.   |
| 61 Webserver error       | Error at start of web server.   | Please contact your distributor.                                    |
| 62 Wrong FPGA            | The direct print module is equipped with the wrong FPGA.                      | Please contact your distributor.                                    |
| 63 End position          | The label length is too long.<br>The number of labels per cycle is too much.  | Check label length res. the number of labels per cycle.             |

| <b>Error message</b>   | <b>Cause</b>   | <b>Remedy</b>   |
|------------------------|--|---|
| 64 Zero point          | Defective photocell.   | Change photocell.   |
| 65 Compressed air      | Pressure air is not connected.   | Check pressure air.   |
| 66 External releaser   | External print release signal is missing.  | Check input signal.   |
| 67 Row too long        | Wrong definition of column width res. number of columns.                                 | Reduce the column width res. correct the number of columns.   |
| 68 Scanner             | The connected bar code scanner signals a device error.                                   | Check the connection scanner/printer.<br>Check scanner (dirty).   |
| 69 Scanner NoRead      | Bad print quality.<br>Printhead completely soiled or defective.<br>Print speed too high. | Increase contrast.<br>Clean printhead or exchange (if necessary).<br>Reduce print speed.                                  |
| 70 Scanner data        | Scanned data does not correspond to the data which is to print.                          | Exchange printhead.   |
| 71 Invalid page        | As page number either 0 or a number > 9 is selected.                                     | Select a number between 1 and 9.  |
| 72 Page selection      | A page which is not available is selected.   | Check the defined pages.  |
| 73 Page not defined    | The page is not defined.   | Check the print definition.   |
| 74 Format user guiding | Wrong format for customised entry.   | Check the format string.  |
| 75 Format date/time    | Wrong format for date/time.  | Check the format string.  |
| 76 Hotstart CF         | No CF card found.  | If option hotstart was activated, a CF card must be inserted.<br>Switch off the printer before inserting the memory card. |
| 77 Flip/Rotate         | Selection of print of several columns and also mirror/rotate.                            | It is only possible to select one of both functions.  |
| 78 System file         | Loading of temporary hotstart files.   | Not possible.   |
| 79 Shift variable      | Faulty definition of shift times (overlapping times).                                    | Check definition of shift times.  |
| 80 GS1 Databar         | General GS1 Databar error.   | Check definition and parameter of GS1 Databar code.   |
| 81 IGP error           | Protocol error IGP.  | Check sent data.  |

| <b>Error message</b>    | <b>Cause</b>   | <b>Remedy</b>  |
|-------------------------|--|--|
| 82 Time generation      | Printing creation was still active at print start.   | Reduce print speed.<br>Use printers' output signal for synchronisation.<br>Use bitmap fonts to reduce generating time.                     |
| 83 Transport protection | Both DPM position sensors (start/end) are active.  | Displace zero point sensor<br>Check sensors in service functions menu  |
| 84 No font data         | Font and web data is missing.  | Run a software update.   |
| 85 No layout ID         | Label ID definition is missing.  | Define label ID onto the label.  |
| 86 Layout ID            | Scanned data does not correspond to defined ID.  | Wrong label loaded from CF card.   |
| 87 RFID no label        | RFID unit cannot recognise a label.  | Displace RFID unit or use an offset.   |
| 88 RFID verify          | Error while checking programmed data.  | Faulty RFID label.<br>Check RFID definitions   |
| 89 RFID timeout         | Error at programming the RFID label.   | Label positioning.<br>Faulty label.  |
| 90 RFID data            | Faulty or incomplete definition of RFID data.  | Check RFID data definitions.   |
| 91 RFID tag type        | Definition of label data does not correspond with the used label.  | Check storage partitioning of used label type  |
| 92 RFID lock            | Error at programming the RFID label (locked fields).   | Check RFID data definitions.<br>Label was already programmed.  |
| 93 RFID programming     | Error at programming the RFID label.   | Check RFID definitions.  |
| 94 Scanner timeout      | The scanner could not read the bar code within the set timeout time.   |  |
|                         | Defective printhead.<br>Wrinkles in transfer ribbon.<br>Scanner wrong positioned.<br>Timeout time too short. | Check printhead.<br>Check transfer ribbon.<br>Position scanner correctly, corresponding to the set feeding.<br>Select longer timeout time. |

| <b>Error message</b>            | <b>Cause</b>   | <b>Remedy</b>  |
|---------------------------------|--|--|
| 95 Scanner layout difference    | Scanner data does not correspond to bar code data.   | Check adjustment of scanner.<br>Check scanner settings / connection.       |
| 96 COM break                    | Serial interface error.  | Check settings for serial data transmission as well as cable (printer-PC). |
| 97 COM general                  | Serial interface error.  | Check settings for serial data transmission as well as cable (printer-PC). |
| 98 No software printhead FPGA   | No printhead-FPGA data available.  | Please contact your responsible distributor.                               |
| 99 Load software printhead FPGA | Error when programming printhead-FPGA.   | Please contact your responsible distributor.                               |
| 100 Upper position              | Sensor signal up is missing (option APL 100).  | Check input signals / compressed-air supply.                               |
| 101 Lower position              | Sensor signal down is missing (option APL 100).  | Check input signals / compressed-air supply.                               |
| 102 Vacuum plate empty          | Sensor does not recognise a label at vacuum plate (option APL 100).                        | Check input signals / compressed-air supply.                               |
| 103 Start signal                | Print order is active but device not ready to process it.                                  | Check start signal.  |
| 104 No print data               | Print data outside the defined label.<br>Selection of wrong module type (design software). | Check selected module type.<br>Check selection of left/right version.      |
| 105 Printhead                   | No original printhead is used.   | Check the used printhead.<br>Contact your distributor.                     |
| 106 Invalid Tag type            | Wrong Tag type.<br>Tag data do not match the Tag type in the printer.                      | Adapt data or use the correct Tag type.                                    |
| 107 RFID invalid                | RFID module is not activated.<br>No RFID data can be processed.                            | Activate RFID module or remove RFID data from label data.                  |
| 108 GS1-128 invalid             | Transferred GS1-128 bar code is invalid.   | Verify bar code data (see GS1-128 bar code specification).                 |
| 109 EPC parameter               | Error at EPC calculation.  | Verify data (see EPC specification).                                       |

| <b>Error message</b> | <b>Cause</b>  | <b>Remedy</b>  |
|----------------------|---|--|
| 110 Housing open     | When starting the print order the housing cover is not closed.  | Close the housing cover and start the print order anew.  |
| 111 EAN.UCC code     | Transferred EAN.UCC code is invalid.  | Verify bar code data (see corresponding specification).  |
| 112 Print carriage   | Printing carriage does not move.  | Check gear belt (possibly broken).   |
| 113 Applicator error | Error while using applicator.   | Check applicator.  |
| 114 Left position    | Left final position switch is not in correct position.  | Check LEFT final position switch for correct function and position.<br>Check function of pneumatics for cross traverse.  |
| 115 Right position   | Right final position switch is not in correct position.   | Check RIGHT final position switch for correct function and position.<br>Check function of pneumatics for cross traverse. |
| 116 Print position   | The print position is not correct.  | Check TOP and RIGHT final position switch for correct function and position.<br>Check pneumatics for function            |
| 117 XML parameter    | The parameters in the XML file are not correct.   | Please contact your responsible distributor.   |
| 118 Invalid variable | Transferred variable is invalid with customized entry.  | Select correct variable without customized entry and transfer it.  |
| 119 No ribbon        | During the print order the ribbon roll becomes empty (rear printhead).<br>Defect at the transfer ribbon photocell (rear photocell). | Change transfer ribbon.<br>Check transfer ribbon photocell (service functions).  |
| 120 Wrong directory  | Invalid target directory when copying.  | Target directory must not be within the source directory.<br>Check target directory.                                     |
| 121 No label found   | No label found at the rear printhead (DuoPrint).<br>Soiled label photocell.<br>Labels not inserted correctly.                       | Insert new label roll.<br>Clean the label photocell.<br>Check if labels are inserted correctly.                          |
| 122 IP occupied      | The IP address was already assigned.  | Assign a new IP address.   |

| <b>Error message</b>   | <b>Cause</b>   | <b>Remedy</b>   |
|------------------------|--|---|
| 123 Print asynchronous | <p>The label photocell do not work in the order as it is expected according to print data.</p> <p>The settings of the photocell are not correct.</p> <p>Settings of label size and gap size are not correct.</p> <p>No label found at the rear printhead.</p> <p>Soiled label photocell.</p> <p>Labels not inserted correctly.</p> | <p>Check label size and gap size.</p> <p>Check label photocell settings.</p> <p>Check correct loading of label material.</p> <p>Insert new label roll.</p> <p>Clean the label photocell.</p> <p>Check if labels are inserted correctly.</p> |
| 124 Speed too slow     | Print speed is too slow.   | Increase the speed of customers' machine.   |





# 11 Additional Information

## 11.1 Column Printing

With this label printer several columns can be printed, i.e. the information of one column can be printed several times (depending on its width) on a label. Caused by this the use of the complete print width is possible and the generating time is enormously reduced.

For example 4 columns with a width of 25 mm or 2 columns with a width of 50 mm can be printed onto a label with a width of 100 mm. Please note that the first label is always the one with the largest x coordinate, i.e. it has the largest distance to the printhead.

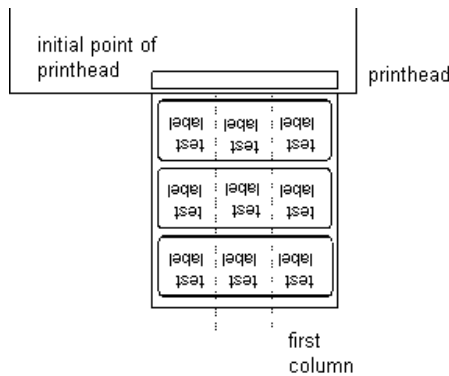

### Setting the print of several columns

Press key **F** to access the function menu.

Press key **→** as long as you arrive the menu *Label layout*.

Press key **●** to confirm the selection.

Press key **→** as long as to the menu item *Width/Columns*.

Press keys **▲** and **▼** to set the label width. The *Width* is the width of one column, e.g. 20.0 mm.

Press keys **◀** and **▶** to arrive the *Column* input field.

Press keys **▲** and **▼** to change the number of columns, e.g. 4 columns with a label width of 20.0 mm.

Press key **■** to start the print with input of number of labels and number of lines. The number of labels corresponds to the number of labels that should be printed.

e.g. Columns: 3, Items: 4

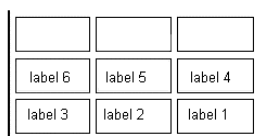

The first four labels were printed but not labels 5 and 6.

## 11.2 Password Protection

**Example 1:** The supervisor programs a Compact Flash Card directly with the label printer. He stores 10 different labels. As well he adjusts the print parameters, like contrast, speed, etc. to the corresponding values. The user is only supposed to read the labels from CF card and to print them. Therefore the supervisor blocks the function menu and the entry function by a password.

**Example 2:** The label printer is connected to a PC. The user is only supposed to take the labels dispensed by the label printer and stick them on. To prevent, that the labels or the label printer set-up will not be changed, the supervisor blocks all device functions (e.g. function menu, entry menu, etc.) by a password.

**Example 3:** The user has to change several texts before printing. It is not allowed to change any masks (fonts, position, etc.). Therefore the supervisor blocks the entry of mask and the function menu. By this means the user indeed can print labels, but the set-up of label printer and the masks of the label cannot be changed.

To receive a most flexible password protection, the device functions will be divided into several function groups:

- 1. Function menu:** In the function menu the print parameters can be changed (contrast, speed, mode, ...). The password protection prevents modifications at the print settings.
- 2. CF card:** With the functions of your Compact Flash Card labels can be stored, loaded, etc. The password protection has to decide if no access or only readable access on CF card is allowed.
- 3. Print functions:** With key **quant** a print can be produced. In case the label printer is connected to a PC, it can be useful, that the user is not able to produce a print manually. So the password protection prevents that prints can be produced manually.

Because of these different function groups the password protection is very flexible. The label printer can be adjusted best to its actual order, as only certain functions are blocked.

**Definition of password**

In case no password is defined res. the password protection is not activated, all functions can be used. In the function menu you will find the menu item 'Password', where the password can be entered and the password protection activated.

Press key  to change to the function menu.

Press key  as long as you arrived the menu *Device settings*.

Press key  to confirm the selection.



Press key  as long as you arrived the menu item *Password*.

Press key  to confirm the selection.

|    |                         |
|----|-------------------------|
| F  | Function menu           |
| CF | Compact Flash functions |
| D  | Print functions         |



If the password protection is active but the function menu not protected, first of all the password (four-digit number, possible values 0000 - 9999) has to be entered. Now the modifications can be made. The user can define the password in the first line (four-digit number).

Press key  to continue.

Press keys  and  to activate/deactivate (Yes/No) the password protection.

Press key  to change to the second line.

Press keys  and  to block/open individual function groups.

Press keys  and  to change to the next group.

|     |                    |                             |
|-----|--------------------|-----------------------------|
| F:  | Function menu      | 0...open                    |
|     |                    | 1...locked                  |
| CF: | Compact Flash card | 0...open                    |
|     |                    | 1...only reading access     |
|     |                    | 2...access blocked          |
| D:  | Device guiding     | 0...open                    |
|     |                    | 1...open                    |
|     |                    | 2...no manual print release |

**Activate blocked function:**

In order to execute a blocked function, first of all the valid password has to be entered.

Press key  to confirm the entry. If the correct password is entered then the desired function can be executed. If a wrong password is entered, no error message appears but the device returns to the main menu.

## 11.3 Photocells



### NOTICE!

When using reflection photocells you should observe that the label printer cover is closed and in this way other light (e.g. working lamp) on the photocell is prevented.

#### **Transmission photocell normal**

For this photocell type the transmitter is at the top res. the receiver at the bottom, i.e. the infra-red light is sent from the top. In this way the label detection is also from the top. This photocell type is used for standard adhesive labels with gap.

#### **Reflexion photocell normal**

For this photocell type the transmitter and receiver are at the bottom, i.e. the light is reflected by the label and taken over from the receiver. This photocell type is used for white (light) continuous labels with a black (dark) bar. The bar is the separator, i.e. it indicates the position of gap and in this way the label start.

#### **Transmission photocell inverse**

For this photocell type the transmitter is at the top res. the receiver at the bottom, i.e. the infra-red light is sent from the top. The label detection is, same as for the **transmission photocell normal**, from the top. However, it is printed differently as for normal photocells, in the translucent place; the label printer recognizes the opaque place as gap. This photocell type is used frequently when printing foils.

#### **Reflexion photocell inverse**

For this photocell type the transmitter and receiver are at the bottom, i.e. the light is reflected by the label and taken over from the receiver. This photocell type is used for black (dark) continuous labels with a white (light) bar. This bar is the separator, i.e. it indicates the position of gap and in this way the start of label.



### NOTICE!

When using transmission photocells inverse, the label printer must measure a difference of 2.5 V and for reflection photocells inverse 1 V between translucent and opaque material. Otherwise the label printer does not recognize a difference between label and gap (bar).

## 12 Environmentally-Friendly Disposal

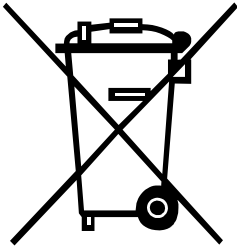

Manufacturers of B2B equipments are obliged to take-back and dispose old equipment which was manufactured after 13 August 2005. In principle, these old equipments may not be delivered to communal collecting points. They may only be organised used and disposed by the manufacturer. Valentin products accordingly labelled can therefore in future be returned to Carl Valentin GmbH.

Thereupon old equipment is professionally disposed.

Thereby Carl Valentin GmbH observes all obligations in the context of old equipment disposal in time and makes therewith the smooth selling of products furthermore possible. Please understand that we can only take-back equipment that is send free of carriage charges.

Further information is available from WEEE directive or our web site [www.carl-valentin.de](http://www.carl-valentin.de).



## 13 Index

### C

|   |        |
|---|--------|
| Column printing .....                         | 87     |
| Compact Flash Card                            |        |
| Change directory .....                        | 63     |
| Copying.....                                  | 67     |
| Define user directory.....                    | 61, 62 |
| Delete file .....                             | 65     |
| Display structure .....                       | 59     |
| Filter .....                                  | 68     |
| Firmware update.....                          | 68     |
| Formatting.....                               | 66     |
| Load file .....                               | 64     |
| Load layout .....                             | 62     |
| Navigation.....                               | 60     |
| Save configuration .....                      | 65     |
| Save layout .....                             | 64     |
| Connecting printer .....                      | 28     |
| Connector pin assignment (printer rear) ..... | 28     |
| Control inputs and outputs .....              | 23     |

### E

|  |                                    |
|--|------------------------------------|
| Environmentally-friendly disposal..... | 91                                 |
| Error messages/Error corrections ..... | 79, 80, 81, 82, 83, 84, 85, 86, 87 |

### F

|                         |                |
|-------------------------|----------------|
| Function menu           |                |
| Date/Time .....         | 52             |
| Device settings .....   | 42, 43, 44     |
| Dispenser I/O.....      | 44, 45, 46     |
| Interface.....          | 51             |
| Label layout .....      | 40, 41         |
| Main menu .....         | 57             |
| Material savings.....   | 48, 49, 50     |
| Menu structure.....     | 36, 37, 38     |
| Network.....            | 50             |
| Print setting.....      | 39             |
| Remote console.....     | 50             |
| Service functions ..... | 53, 54, 55, 56 |

### I

|                     |        |
|---------------------|--------|
| Inputs/outputs..... | 22, 24 |
| Installation .....  | 27     |
| Instructions .....  | 5      |
| Intended use.....   | 5      |

### K

|                |    |
|----------------|----|
| Keyboard ..... | 35 |
|----------------|----|

### L

|                       |    |
|-----------------------|----|
| Loading media         |    |
| Tear-off mode .....   | 31 |
| Transfer ribbon ..... | 33 |

**M**

|                                       |        |
|---------------------------------------|--------|
| Maintenance/cleaning                  |        |
| General cleaning.....                 | 70     |
| Label photocell cleaning .....        | 73     |
| Maintenance schedule.....             | 69     |
| Print roller cleaning .....           | 70, 71 |
| Printhead adjusting.....              | 76     |
| Printhead cleaning.....               | 72     |
| Printhead, replacing.....             | 74, 75 |
| Ribbon drawing roller, cleaning ..... | 70     |
| Material, loading .....               | 31     |

**O**

|                            |              |
|----------------------------|--------------|
| Operating conditions ..... | 8, 9, 10, 11 |
|----------------------------|--------------|

**P**

|                          |        |
|--------------------------|--------|
| Password protection..... | 88, 89 |
| Photocells .....         | 90     |
| Printhead adjusting      |        |
| Parallelism .....        | 76     |
| Pressure.....            | 77     |
| Pressure balance.....    | 76     |

**S**

|                           |    |
|---------------------------|----|
| Safety Instructions ..... | 7  |
| Setting up printer .....  | 27 |
| Start-up.....             | 29 |

**T**

|                               |        |
|-------------------------------|--------|
| Two-colour printing           |        |
| Colour processing.....        | 16, 17 |
| Correcting the printout ..... | 15     |
| Error correction .....        | 17     |
| Label design .....            | 13     |
| Label photocells.....         | 14     |
| Label saving.....             | 15, 16 |
| Printhead 2 Offset.....       | 14     |
| Test print.....               | 15     |

**U**

|                          |    |
|--------------------------|----|
| USB Stick                |    |
| Change directory .....   | 63 |
| Copying.....             | 67 |
| Delete file.....         | 65 |
| Display structure .....  | 59 |
| Filter .....             | 68 |
| Firmware update.....     | 68 |
| Load file .....          | 64 |
| Load layout .....        | 62 |
| Navigation.....          | 60 |
| Save configuration ..... | 65 |
| Save layout .....        | 64 |







---

Carl Valentin GmbH  
Neckarstraße 78 – 86 u. 94 . D-78056 Villingen-Schwenningen  
Phone +49 (0)7720 9712-0 . Fax +49 (0)7720 9712-9901  
info@carl-valentin.de . www.carl-valentin.de